

Application Note

How It Works - Surface Plate Lapping Spot-Checker™

System Recommendation:
L-703SP Surface Plate Calibration System

One of the annoying parts of using electronic levels when resurfacing a surface plate is you have to shoot the entire plate for flatness to see how the lapping process is going. This takes a lot of time! With the L-703SP Surface Plate Calibration Systems and our Lapping Spot Checker™, you can do quick-checks of a single line segment in about 5 minutes to see how much the flatness error has been reduced. Typically, you'll pick the line segment with the highest flatness error and focus on it as you lap the plate.



Lapping Spot Checker™ Features:

- Click on any line segment in the *Current Line Selection* table to automatically load the line data from one of the plate line segments from the plate calibration file.
- Set up the laser to check any line segment in about 5 minutes
- After lapping, record data for a line segment up to 5 times.
- Plane6 automatically calculates (zeroing endpoints) flatness for the line.
- Plane6 automatically graphs the line flatness and color codes the runs.
- After checking the flatness of a line, use the *Dump to Grid* button to send the alignment values back into the overall plate data, replacing the old line data. Then, Plane6 will use this new data to calculate the new plate flatness without having to measure the entire plate.



Hamar Laser Instruments, Inc.
5 Ye Olde Road Danbury, CT 06810
Phone: 800.826.6185 Fax: 203.730.4611
Int'l: +1.203.730.4600
E-mail: sales@hamarlaser.com www.hamarlaser.com
[Click here](#) for a list of our distributors.



How it Works - Lapping Spot Check™ Procedure

Here is a procedure to quickly spot-check a line segment for flatness after you have finished the lapping and cleaned the plate.

Step 1 – Open Calibration File

If it is not already open, then open the calibration file for the plate you want to lap.

Step 2 – Open Step 2 and Select Line Checker Tab

Go to Step 2 and click on the Line Tab at the top of the screen to open the screen.

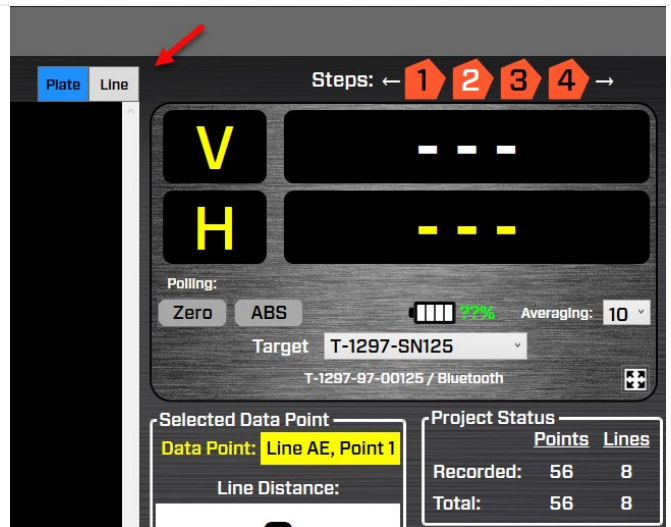

Step 3 – Select Line From Table

From the *Current Line Selection* table, select the line segment you want to focus on. This will take the line segment flatness data from the plate calibration file and load it into the top of the screen. In this example, we use line AE.

The line segment data (from the plate data) is shown in top row along with the segment identifier.

- **Grid R row** - This is the line “as-recorded” segment data from the overall plate calibration.
- **Grid C row** – this is the “corrected” data (zero end points) for the line, showing the overall flatness values.

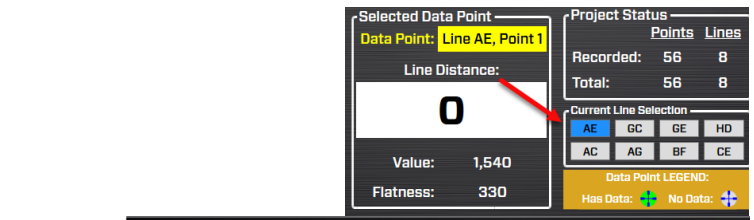

Step 2: Data Collection

	AE	Point 1	Point 2	Point 3	Point 4	Point 5	Point 6	Point 7
Grid R		1,540	1,570	1,810	2,050	2,350	2,800	3,230
Grid C		0	-240	-290	-330	-310	-150	0
L1	R	--	--	--	--	--	--	--
	C	--	--	--	--	--	--	--
L2	R	--	--	--	--	--	--	--
	C	--	--	--	--	--	--	--
L3	R	--	--	--	--	--	--	--
	C	--	--	--	--	--	--	--
L4	R	--	--	--	--	--	--	--
	C	--	--	--	--	--	--	--
L5	R	--	--	--	--	--	--	--
	C	--	--	--	--	--	--	--

Each line in the grid is graphed at the bottom of the screen.

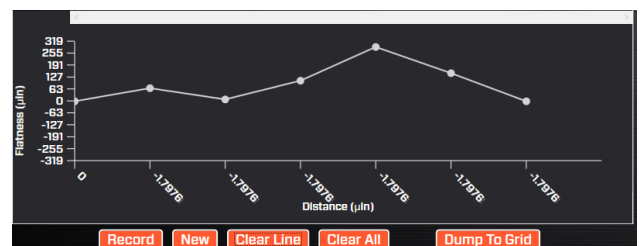

Step 4 - Set Up Laser Line & A-703SP-LM

Select the line segment you want to measure and select the matching length for the A-703SP-SE Straight Edge ruler. Use the corner/midpoint locating tool to set up the straight edge as shown above in the Plane6 Software Manual on pages 35, 41 or 42.

Then place the L-703SP-LM Laser Fixture on the straight edge as shown above.



Step 5 – Check Laser Setup

Before taking data, it's a good idea to make sure the laser is still reasonably parallel to the A-703SP-LM Laser Mount. So Bring the T-1297 Target and A-1297-SP Target-Measuring Base to the first measuring point (line distance zero) as you did above. Zero the display by clicking on the **Zero** button.

Note - Due the extremely high resolution, it's expected that the value won't be exactly zero due to some measurement noise but they will be close.

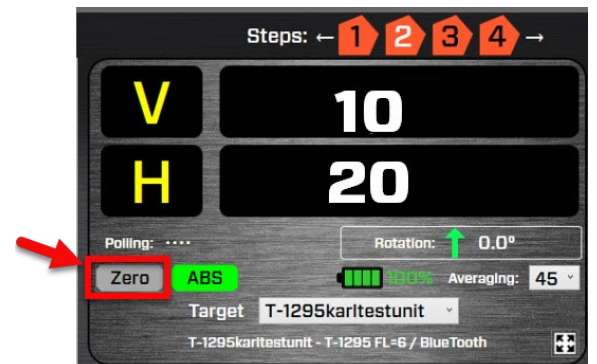
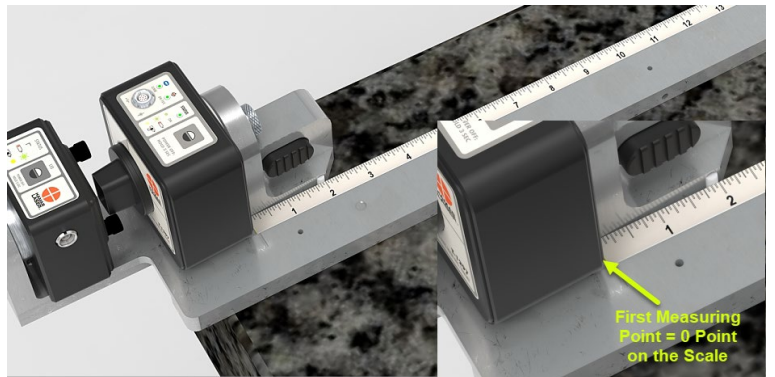

Step 6 - Move Target to Far Point and Adjust Laser's Pitch/Yaw

Move T-1297/A-1297-SP Base to the far end of the straight edge. If the values are greater than $250 \mu\text{in}/\text{ft}$ ($2 \mu\text{m}/\text{m}$), then adjust the Pitch and Yaw knobs on the laser until you the H&V values are within spec. For example, if the length of the line is 5 feet, then you would adjust until you got the H & V values less than $5 \times 250 = 1,250$.

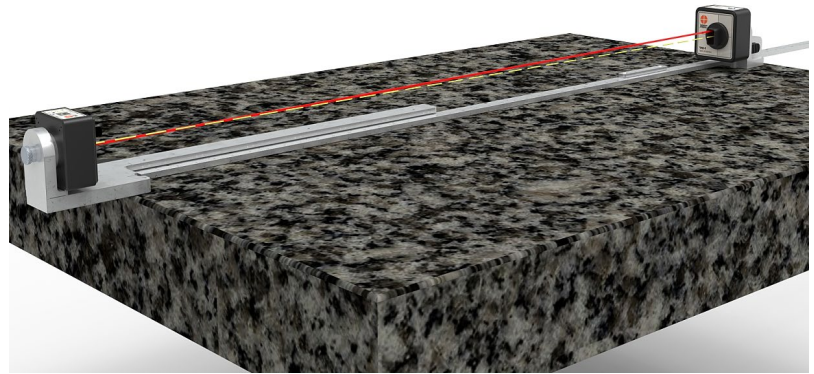

Step 7 – Record Values for first line check

Put the T-1297 target at the zero point and hit *Record*. Record the rest of the points along the line following the *Selected Data Point* box, which displays the location on the ruler where to place the target.

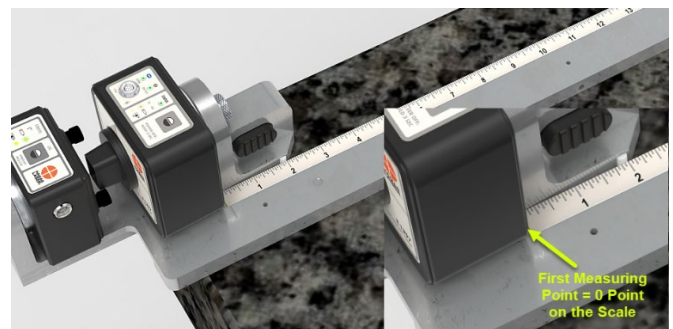
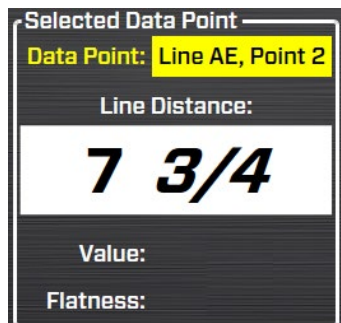

Step 8 – View Results

When you're done recording the values for AE, you'll see the raw data (R) in row L1. You will also see the corrected data (C), where the end points are zeroed and the max value represents the overall flatness for the line. In the example to the right, the max value is 200 μin .

If this is within your tolerance, then you can click *Dump to Grid* (under the graph). This will automatically upload the new values into the line AE values in the overall calibration data in the *Plate* tab. You can then go to Step 3 and Plane6 will recalculate the calibration analysis, so you can see how the new line of data affected the overall calibration of the plate.



Step 9 – Continue to Lap and Record Data

If the first run at lapping the plate did not help the plate to pass calibration, then you can lap it again and then record a new set of line of data. If row L1 is filled with data, then when you click *Record*, it will automatically start filling in row L2. When you're done, as before, it will calculate the corrections and display the results in row C. The graph will also show the line graph for the new set of data.



Each new row of data is plotted with the color matching the row label color and you can record up to 5 sets of data for each line segment.

If the data looks good, then you should record a new set of plate data to verify the calibration by clicking *Save New File for Existing Project* and Plane6 will create a clean file with the plate dimensions preloaded that will be saved in the plate's project folder.

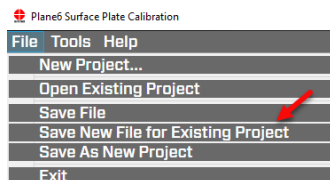

Plane6 Sample Report



Plane6
Repeat_3 Results

Plate Grade: B
Flatness (Max-Min): 440 X
Tolerance: 200
Units: μ m

X Dimension: 39.13
Y Dimension: 27.13

Line BF Center Value: -10 ✓
Line DH Center Value: -10 ✓
Center Intersection Tolerance: 100

Plate Serial Number: 7490-89R
Technician Name:
Contact Info:
Recording Date:
Recording Time:
Temperature (Top): 72.4
Temperature (Bottom): 74.8
Project Notes:

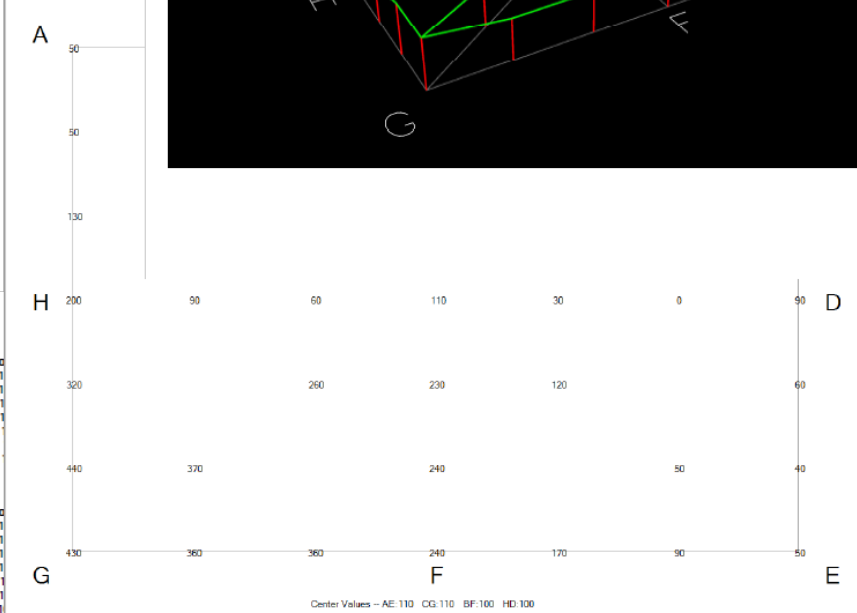
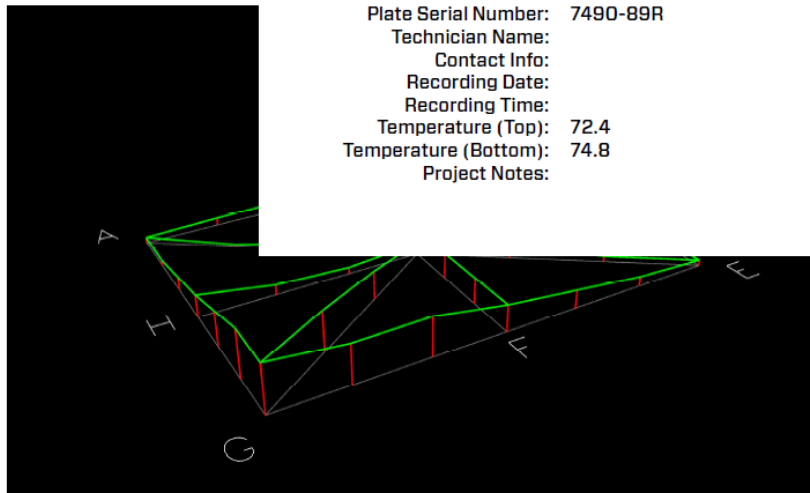

Point # Co

1	1
2	1
3	1
4	1
5	1
6	1
7	1

Point # Co

1	1
2	1
3	1
4	1
5	1
6	1
7	1

Point # Co

1	1
2	1
3	1
4	1
5	1
6	1
7	1

Center Values -- AE:110 CG:110 BF:100 HD:100

Point # Co

1	1
2	1
3	1
4	10,750
5	10,870
6	10,940
7	10,910

4	10,750	-30	90
5	10,870	-50	60
6	10,980	-70	40
7	11,140	-60	50

Line HD

Point #	Collected	Ends to Outer Center	Zero Low Point
1	10,750	90	200
2	10,630	-20	90
3	10,590	-50	60
4	10,630	-10	100
5	10,550	-80	30
6	10,510	-110	0
7	10,590	-30	90

Line BF

Point #	Zero Line Ends	Ends to Outer Center	Zero Low Point
1	10,710	50	160
2	10,630	-60	50
3	10,670	-50	60
4	10,750	-10	100
5	10,910	120	230
6	10,940	120	240
7	10,980	130	240