

*L-703SP Surface Plate
Calibration System*

**Revision A11
September 2024**



HAMAR LASER INSTRUMENTS, INC.
www.hamarlaser.com

5 Ye Olde Road, Danbury, CT 06810
Ph: +1-203-730-4600
Fax +1-203-730-4611

WARRANTY

Hamar Laser Instruments, Inc., warrants each instrument and other articles of equipment manufactured by it to be free from defects in materials and workmanship under normal use and service, its obligation under this warranty being limited to making good at its factory any instrument and other article of equipment which shall within one year after shipment of each instrument and other article of equipment to the original purchaser be returned intact to Hamar with transportation prepaid, and which Hamar's examination shall disclose to Hamar's satisfaction to have been thus defective; other than this express warranty, Hamar neither assumes nor authorizes any other persons to assume for it any other liability or obligation in connection with the sale of its products.

This warranty is not applicable to instruments or other articles of equipment manufactured by other companies and limited by a warranty extending for less than one year. In such an event, the more limited warranty applies to said instrument or article of equipment.

This warranty shall not apply to any instrument or other article of equipment which shall have been repaired or altered outside the Hamar factory, nor which has been subject to misuse, negligence, or use not in accord with instructions furnished by the manufacturer.

The software described in this manual is furnished under a license agreement and may be used or copied only in accordance with the terms of the agreement. It is against the law to copy the software on any medium for any purpose other than the purchaser's personal use.

The information in this manual is subject to change without notice. No part of this manual may be reproduced by any means, electronic or mechanical, without written permission from Hamar Laser Instruments, Inc.

**© Copyright Hamar Laser Instruments, Inc., 2024
5 Ye Older Road, Danbury, Connecticut 06810**

Table of Contents

L-703SP Surface Plate Calibration System	1
System Components	1
Computer System Requirements	1
System Features	1
L-703SP Surface Plate Calibration System - Hardware Overview	2
Surface plate calibration	2
Linear guideway straightness.....	2
Flatness/straightness of large parts	2
L-703S Laser Control Panel and Functions	2
The I/O and Status LEDs	2
L-703S Laser Modes	2
L-703S Angular Adjustments	3
L-703S Angular Adjustments – Returning Adjustments to the Center of their Range	3
L-703S Level Vials	4
L-703SP Surface Plate Calibration System - Hardware Overview	5
The T-1297 3-Axis Wireless Spindle & Straightness Target.....	5
How to Use the T-1297 Targets.....	5
How to Pair the T-1297 Target’s Bluetooth to a PC.....	7
L-703SP Surface Plate Calibration System - Hardware Overview	9
A-703SP-LM Surface-Plate Mounting Fixture	9
A-1297-SP High Accuracy, Flatness Measuring Base for T-1297 Target.....	11
A-703SP-SE-A/B/C/D Target Straight-Edges and Rulers.....	12
Selecting Straight Edge Length	13
Preparing for an Alignment	14
Cleaning the Plate.....	14
Maintenance and Cleaning of L-703SP & T-1297.....	14
Target Calibration	14
Plane6 Surface Plate Calibration Software - System Requirements.....	16
Installing Plane6	16
Getting Started with Plane6	17
Hamar Product Registration	17
Creating a New Project File or Opening an Existing Project File.....	18
Converting Raw Data Values in CSV files to Inches or Millimeters	19
Restoring File Backups	19
Plane6 Software – Summary of Main Screens	20
Plane6 Screens - File Menus.....	22
The File Menu	22
The Tools Menu	22
Navigating Plane6 with the Status Bar.....	23
Plane6 Screens - Preferences	24
Project Information	24
Targets - Setup Procedure	26
Plane6 Screens - Step 1: Dimensions and Tolerances	29
Plane6 Screens - Step 2: Data Collection	31

Plane6 Screens - Step 3: Results	34
Plane6 Screens - Step 4: Graph.....	36
Interpreting the Plus and Minus Signs in the Live Displays.....	37
L-703SP - How It Works	38
Step-by-Step Surface Plate Calibration Procedure	38
L-703SP - How It Works	50
Performing a Flatness Quick-Check on a Line-Segment after Lapping.....	50
Appendix A – Installing Additional Microsoft Software	55
Installing Microsoft .NET Framework 4.....	55
Appendix B – ANSI B89.3.7.2013 Standard Tolerance Table.....	56

L-703SP Surface Plate Calibration System

The L-703SP Surface Plate Calibration System has been designed to quickly and very accurately check the calibration of surface plates using the Moody Method, following the ASME B89.3 Standard for Surface Plate Calibration. It uses Plane6 Surface Plate Calibration Software and specially designed fixtures to give a high degree of accuracy when calibrating surface plates.

System Components

The L-703SP Surface Plate Calibration System - includes the following components:

- L-703S Spindle & Straightness Laser
- T-1297 3-Axis Wireless Straightness Target with .00001 in. (0.25 μ m) Resolution, 10x10 PSD, Bluetooth & Center/Scan Mode
- A-703SP-LM Surface-Plate Mounting Fixture for L-703SP Laser
- A-1297-SP High Accuracy, Flatness Measuring Base for T-1297 Target
- A-703SP-SE-A Target Straight-Edge and Ruler – 18 in. (457 mm)
- A-703SP-SE-B Target Straight-Edge and Ruler – 36 in. (914 mm)
- A-703SP-SE-C Target Straight-Edge and Ruler – 54 in. (1,373 mm) – 2 pieces
- A-703SP-SE-D Target Straight-Edge and Ruler – 72 in. (1,829 mm) - 2 pieces
- S-1409 Plane6 Surface-Plate Calibration Software for Win 7/8/10/11
- A-818 Shipping Case for L-703/L-705 Spindle & Extruder Systems
- A-819 Shipping Case for L-703SP Straight-Edges and A-703SP-LM

Computer System Requirements

- Physical memory (RAM): 8 GB recommended
- Processor: Intel Pentium4 or later version or AMD equivalent, 1.3 GHz minimum speed
- Available Hard Drive space: 20 GB minimum
- Video Resolution: 1366 x 768 minimum (32-bit color) with hardware acceleration and dedicated video memory.
- Windows 8/10/11 professional editions.
- Bluetooth 2.0 and higher

System Features

- Geometry laser, not interferometer with resolution of 10 μ m. (0.25 μ m).
- Fast, easy setup – 30-40% faster than levels
- Super-linear PSD sensor with <0.25% linearity error
- Bluetooth wireless with 100 ft. (30 m) range
- 3-point measuring base accommodates nearly any measuring increment
- Kit includes a set of straight-edge rulers for fast setups for plates up to 72 in. diagonal. Optional add-on straight edges are available for diagonals up to 126 in. (3.2m).
- Also includes corner & midpoint, straightedge-locating tools to position the straight edge so that the target is located directly on the measurement line.
- Plane6 Surface Plate Calibration Software corrects setup errors and quickly records data, producing calibration report with graph
- Plane6 software runs on most typical Windows® laptops/tablets running Win 8/10/11.
- Li-Po rechargeable batteries for laser/ target with 14+ hrs life

L-703SP Surface Plate Calibration System - Hardware Overview

This section describes the equipment and operation for calibrating surface plates using Hamar Laser's L-703SP Surface Plate Calibration Laser System. The system includes the laser, targets, fixtures, and software.

L-703S Spindle & Straightness Laser - Features and Setup

- Operating range of 50 ft. (15 m).
- Pitch and yaw angular adjustments with a resolution of .00002 in/ft (1.6 $\mu\text{m}/\text{m}$) and adjustment range of $\pm 0.36^\circ$ (± 0.075 in/ft. or ± 6.26 mm/m).
- A .4995 in. (12.69 mm) mounting stud with the laser beam concentric to $< .0003$ in. (0.008 mm).
- Under good environmental conditions, it is accurate to .0015 in. (0.075 mm) in 50 ft. (15 m).
- Rechargeable Li-Ion battery with 20+ hours of battery life.



Figure 1 - L-703S Laser

The L-703S is mounted directly in the A-703SP-LM Surface-Plate Mounting Fixture and aligned to the T-1297 Target located at the end of the line segment. This provides a straight reference line for checking the flatness of the line segment and the rest of the surface plate.

Applications include:

- Surface plate calibration
- Linear guideway straightness
- Flatness/straightness of large parts

L-703S Laser Control Panel and Functions

The I/O and Status LEDs

- *Battery Status LED* – green – normally it is off.
 - Blinks when the battery is low.
 - Solid green when the battery is charging. Turns off when the battery is fully charged.
- *I/O LED* – indicates the laser is turned on. This is also the mode indicator for the laser mode (see Laser Modes below).

The On/Off Button

Press the **I/O** button once to turn it on and press and *hold* for 3 seconds to turn it off. The I/O LED will illuminate when the power turns on.

L-703S Laser Modes

There are 2 laser modes:

1. **Double-Blink Mode** (default) – this is used for the T-1295/T-1296/T-1297 Targets only. The I/O LED will blink twice and pause, blink twice and pause, and will do this continuously.
2. **Fixed (Continuous) Beam mode** – the laser beam is turned on continuously and does not blink. This is used for legacy targets using the R-358 Computer Interface or R-307/R-307V Readouts. The I/O LED will be continuously on (no blinking).

To change the mode, press the **I/O** power button once – do not press and hold, just press one time.

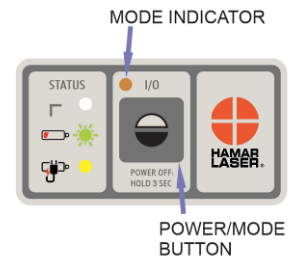

Figure 2 - L-703S Power Overlay

A/C Connector

The L-703S comes with a rechargeable battery. The connector is shown in Figure 3. To connect it, line up the red dot on the A/C adapter plug with the red line on the connector.

L-703S Angular Adjustments

The L-703S comes with pitch (vertical) and yaw (horizontal) angular adjustments to adjust (tilt) the laser to align it to reference points or a rotation axis. The angular adjustments have resolution of .00002 in./ft (0.0016 mm/m) and an adjustment range of $\pm 0.36^\circ$ (± 0.075 in./ft or ± 6.26 mm/m)



Figure 3 - The L-703S - Laser A/C Adapter Connector

<i>L-703 Specifications</i>		
Beam Centering to Mount	.0003 in.	0.008 mm
Angular Range (slope)	± 0.08 in./ft.	6.6 mm/m
Angular Range (deg.)	± 0.38 deg.	
Angular Resolution	.00002 in./ft.	0.0016 mm/m



Figure 4 - L-703S Laser showing Pitch & Yaw Adjustments

L-703S Angular Adjustments – Returning Adjustments to the Center of their Range

To start an alignment, it is best to return the L-703S's angular adjustments to the middle of their range. The middle of the range is when the knob is flush with the overlay (see below). If the knob is unscrewed all the way, then knob will come out but this will not harm the mechanism, so just screw it back in. If the knob is screwed in, then it will also go into the face plate about .25 in. (10 mm).

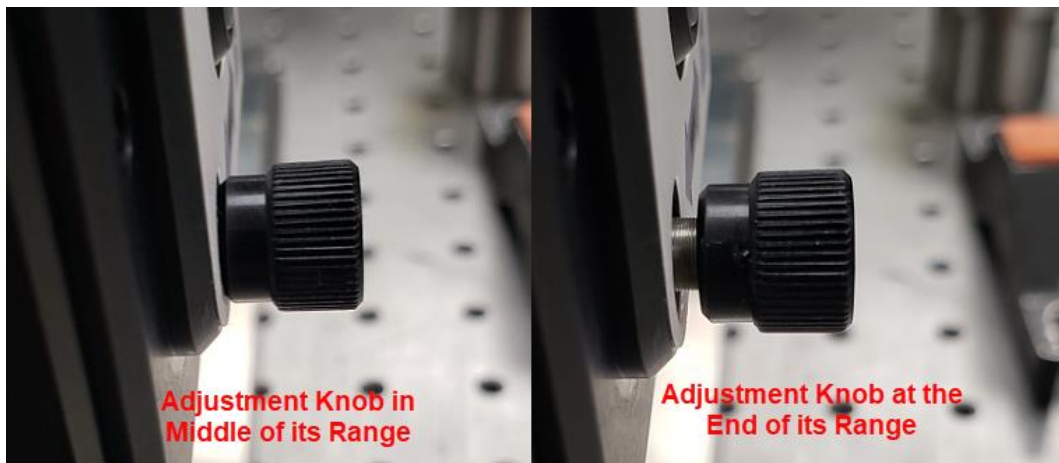

L-703S Level Vials

When using the L-703S in machine tools, we typically will do measurements with the laser at the NORMAL position (12:00) and then rotated with the spindle 180 degrees to the INverted position (6:00). There are level vials on the *side* of the laser to help you know if the laser is directly at 12:00 or 6:00. However, this is not typically used in surface plate calibration, so they are not used in this application.

To use the level, rotate the laser 90 degrees so that the control panel is on the side (i.e. at 3:00 or 9:00). Then slowly rotate the spindle until the bubble is centered in the circle. This indicates the laser is ready to be aligned to the rotation axis.



Figure 5 - L-703 Level Vial

L-703S Warmup Period

IMPORTANT!

We recommend that the user let the laser warm up for at least 30 minutes for the lower accuracy plate grades and for 40-45 minutes for the high accuracy grades. To warm it up, simply turn it on and let it run for the recommended time.

The warmup period allows the internal mounting hardware to thermally grow to a stable state, which reduces the variability in the measurement.

It is also very important to let the target and mounting hardware warm up to ambient temperature especially if they have been stored in an environment that is more than 10 degrees from the ambient temperature.



L-703SP Surface Plate Calibration System - Hardware Overview

The T-1297 3-Axis Wireless Spindle & Straightness Target

Hamar Laser's T-1297 3-Axis Wireless Spindle & Straightness Target is designed work with our L-703S Spindle & Straightness Laser. With Bluetooth communication and multiple measuring axes, the T-1297 target is a multi-purpose target that can be used for many different applications.

- Offers 2 measurement modes:
 - ❖ *Center Mode* - 2-axis center measurement for use with the L-703S Spindle laser.
 - ❖ *Flatness (Scan) Mode* - single-axis flatness measurement for use with our series of auto-rotating lasers (L-730/L-740/L-702SP) in Scan Mode. *(Note – Scan Mode is not used with the L-703S Laser nor used for surface plate calibration.)*
- PSD (Position Sensing Detector) Size:
 - ❖ .39 x .39 in. (10x10 mm) PSD
- Resolution (2 axis & 1 axis): .00001 in. (0.00025 mm)
- Wireless communication via Bluetooth Class 1 radio with 100 ft. (30 m) of communication range.
- Accuracy: error is < 0.25% of the measurement
- PSD concentric to the mounting stud to < .0003 in. (0.008 mm).
- The T-1297 is designed so the measuring plane of the target is right at the face plate of the mounting stud, so when used with the A-1297 High-Accuracy Flatness-Measuring Base, it achieves the highest accuracy possible.
- Accelerometer rotation axis (3rd axis) helps to orient the PSD sensor axes to the alignment axes of the spindle.
- Lithium polymer rechargeable battery with 14 hours of battery life.



Figure 6 - T-1297 3-Axis Wireless Spindle &

How to Use the T-1297 Targets

The T-1297 Targets are designed for use with the L-703S in Double-Blink Mode (center/angular measurements) or Scanning Beam Mode (flatness measurements using one of our scanning laser plane lasers). The targets have a .4995 in. (12.69 mm) mounting stud for mounting spindles and fixtures, such as the A-1297 High-Accuracy Flatness Measuring Base.

Note – this section describes the full functions of the T-1297 Targets. For surface plate calibration applications, the L-703S Spindle Laser and the T-1297 are used only in Center Mode.

T-1297 Center Mode with the L-703S Spindle Laser

This is the default mode when the target is turned on and is what is used with the L-703S Spindle Laser and Plane6 Software. It is recommended while in Center Mode to use the light/dust shield, which is held in place with magnets. While in this mode, the values shown in Plane6 Software displays show the center (offset) values of the target's mounting stud relative to the laser beam. It follows the same sign convention as shown **on Page 37, Interpreting the + and – Signs in the Live Displays.**

T-1297 Scanning Laser Mode - Optional

For applications other than surface plate calibration, the T-1297 Targets can be converted to Scanning Mode and used with the auto-rotating laser planes in our L-702SP and any L-730/L-740 Series lasers. These lasers automatically rotate to create a laser plane, which can then be measured with the T-1297.

Note: The T-1297 in Scan Mode is not compatible with the L-703S Spindle Laser

To change the T-1297 target into Scanning Mode, make sure the laser is *turned off* or the laser beam is blocked. Then press and hold the Power Button (see **Figure 7**). The **ON-TGT LED** will blink instead of being continuously on, as it is when it's in **2-Axis Center Mode**. To return the T-1297 to **2-Axis Center Mode** power down the target and turn it back on.



Figure 7 - T-1295/1296 Control Panel

Note: Plane6 Software does not support Scan Mode. To use Scan Mode, you must purchase MultiTurn10 or Plane5 Software. Please see those manuals for more details.

T-1297 Target LEDs

The T-1297 LED's have several colors and actions to indicate certain functions:

Bluetooth LED Green – means the target is connected to the computer

Bluetooth LED Green/Yellow – alternating green/yellow means the target is communicating with Plane6 software

On Tgt LED Continuous Green – means the target is detecting the laser beam in Center Mode.

On Tgt LED Continuous Red – means the target is not detecting the laser beam in Center Mode.

On Tgt LED Blinking Green – means the target is detecting the laser scan plane in Scan Mode.

On Tgt LED Blinking Red – means the target is not detecting the laser scan plane in Scan Mode.

Battery LED Green – means the target is turned on.

Battery LED Yellow - means the target is charging. It will turn off when fully charged.

Battery LED Blinking Yellow – means the target needs to be charged.



Charging the T-1297

The T-1297 comes with a USB charging cable that plugs into the top of the target. Simply line up the red dot on the connector with the red dot on the female connector on the top of the target.

Please note:

- 1. The LED will flash for 0.25 seconds and turn off if the battery is fully charged.*
- 2. Charging the battery will generate heat and can cause thermal growth in the target, which could add additional uncertainty to the measurements. We recommend charging the target prior to starting the measurements. Also when the battery capacity gets low, it will also generate heat, so make sure to charge the battery when it gets below 20%.*

How to Pair the T-1297 Target's Bluetooth to a PC

For your computer to see the Bluetooth device, you need to turn it on.

1. Tap on **Start** (the Microsoft Logo) > **Settings**.
2. Navigate to **Devices** and go to **Bluetooth**

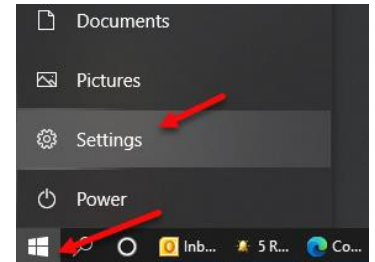

Or click on the **Bluetooth** icon in the system tray and click on Add a **Bluetooth Device**.

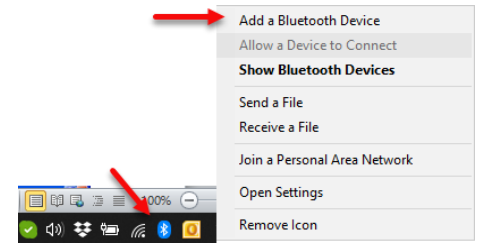

3. Make sure the Bluetooth toggle is in the **On** position. (You'll know it is working because you'll notice the message that reads "Your PC is searching for and can be discovered by Bluetooth devices.")
4. Click on **Add Bluetooth or other device**
5. Select the device type you want to connect (usually you will select **Bluetooth**). You will see the devices listed under **Add a Device**.

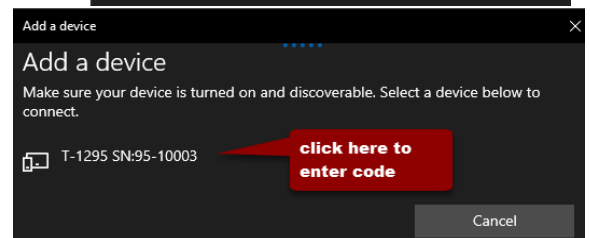
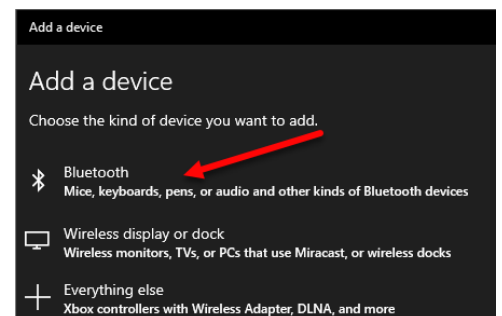
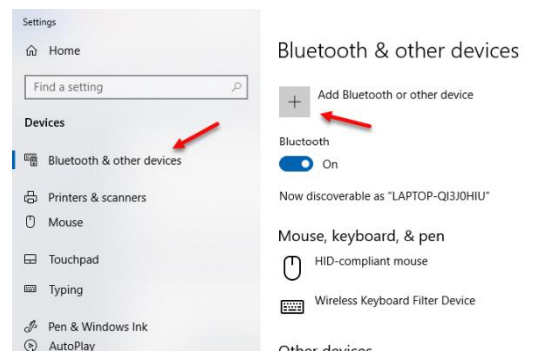

6. Enter **1280** for the passcode when prompted and hit **Connect**. Your Target is now paired and ready to be used. Exit Settings window

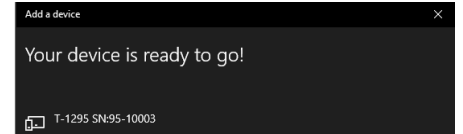
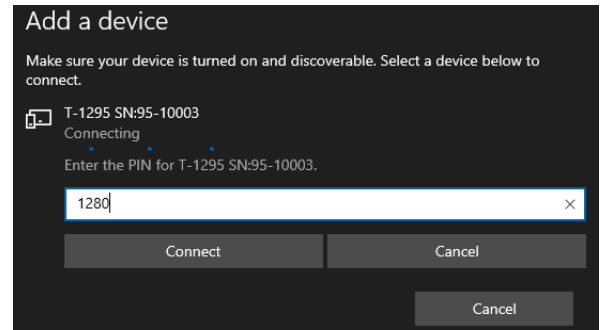

L-703SP Surface Plate Calibration System - Hardware Overview

A-703SP-LM Surface-Plate Mounting Fixture

To accurately measure the flatness of surface plates, the L-703SP requires a stable mounting fixture to hold the laser and a special flatness-measuring base for the target to achieve the highest accuracy possible.

The A-703SP-LM is used to mount the L-703S (see **Figure 8**) on flat surfaces for measuring:

- Flatness measurements of surfaces, such as surface plates.
- Flatness, straightness & squareness measurements of machine tool axes.

To secure the laser in the A-703SP-LM, insert the mounting stud into the .4995 in. (12.7 mm) mounting hole in the fixture. Then use the thumb screw to tighten the mounting stud. Make sure to make it very tight to ensure a rigid mount and avoid laser drift issues.

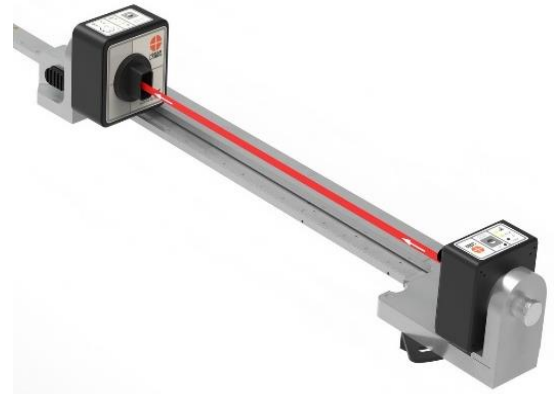

Figure 8 - A-703SP-LM Surface-Plate Mounting Fixture

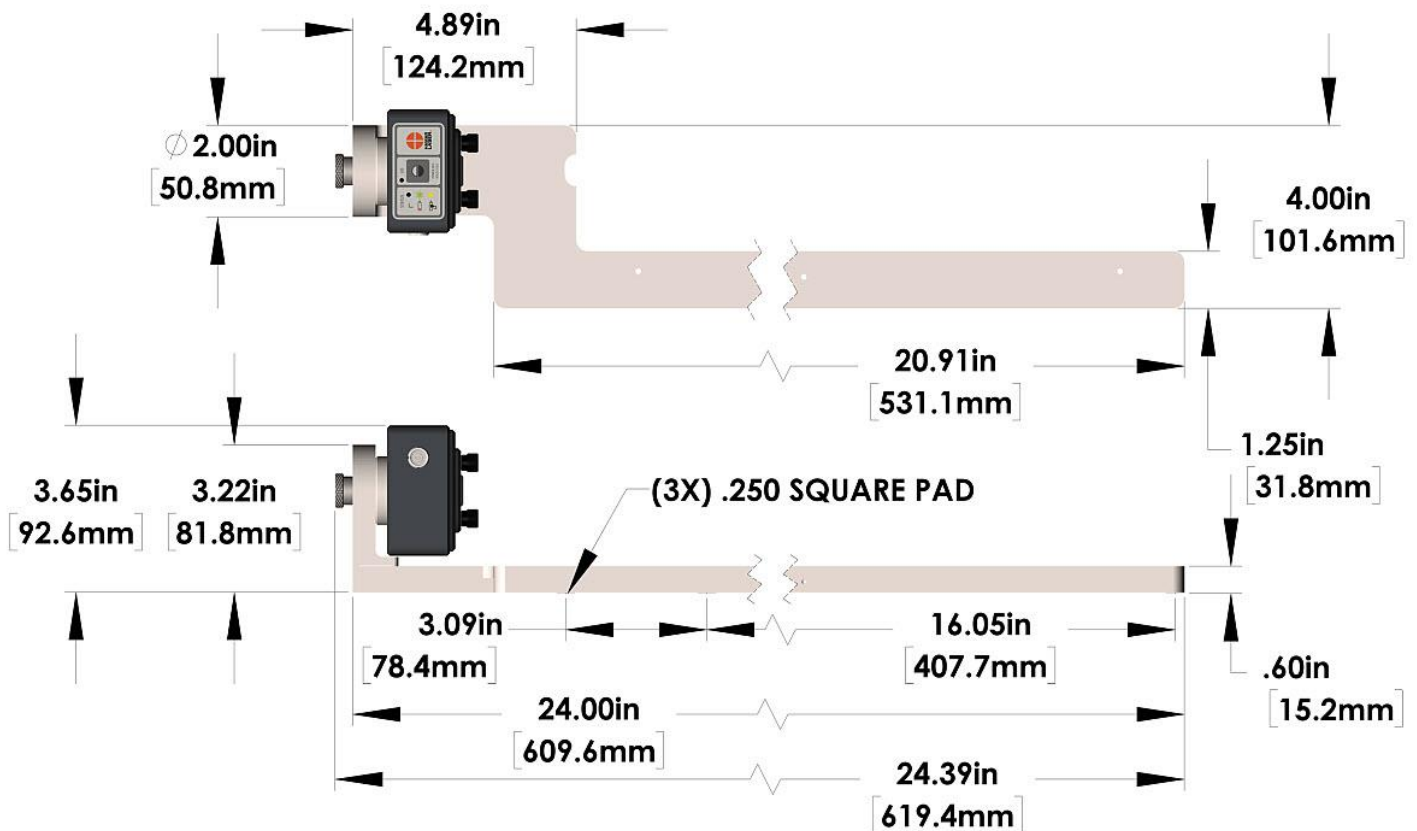

Figure 9 - A-703SP-LM Laser Mounting Fixture Dimensions

Please note - for surface plates smaller than 24 inches (611 mm), there is a second mounting foot (pad) location that is approximately 10 inches (250 mm) from the back mounting foot, so the A-703SP-LM can be used on plates as small as 12x12 in.

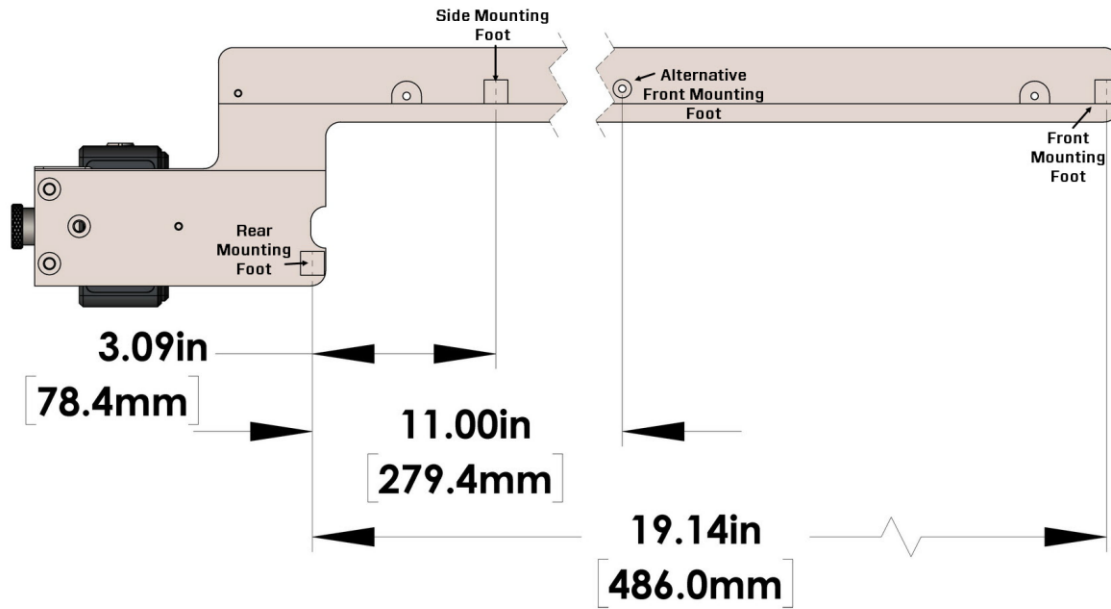

Figure 10 - A-703SP-LM Laser Mounting Fixture Dimensions - Bottom

*****Important Note when Handling the L-703SP-LM Laser Fixture*****

It is very important to note that wearing thin gloves to insulate the heat from your hands is an important good practice when handling the L-703SP-LM. When you hold the L-703SP-LM in your hand, it will grow thermally and this will happen remarkably fast! Keep in mind that a small micro change in the metal upright can cause an angular change in the mounting surface, tilting the laser, which can turn into a significant change in the measurement value when the target is located several feet away.

We also recommend waiting 30-45 seconds after setting down the fixture before taking data. This gives the fixture time to settle down and stabilize. Of course, if the plate being measured is a B-grade plate, then these precautions are less important and can be set aside in the interest of time.

Finally, do NOT touch the L-703SP-LM during the measurement of the line. This can cause the laser beam to move and add uncertainty to the measurement. If you touch it, wait 30 seconds for the movement to settle down and then record the point.

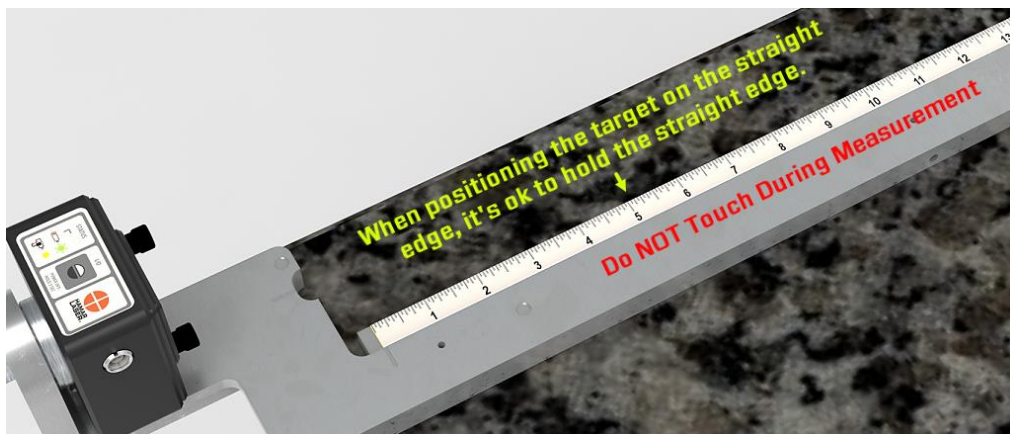

A-1297-SP High Accuracy, Flatness Measuring Base for T-1297 Target

A-1297-SP is used to mount the T-1297 Target (see **Figure 11**) to measure flatness of the plate for measuring:

- Flatness measurements of surfaces.
- Flatness, straightness & squareness measurements of machine tool axes.

Insert the T-1297 Target into the .4995 in. (12.7 mm) mounting hole, making sure to insert the alignment pin (see **Figure 11** and Step 4, starting on Page 38) into the smaller hole below the main hole. Make sure to tighten very tight to ensure a rigid mount and repeatability issues.



Figure 11 -- A-1297-SP High Accuracy, Flatness Measuring Base for T-1297 Target

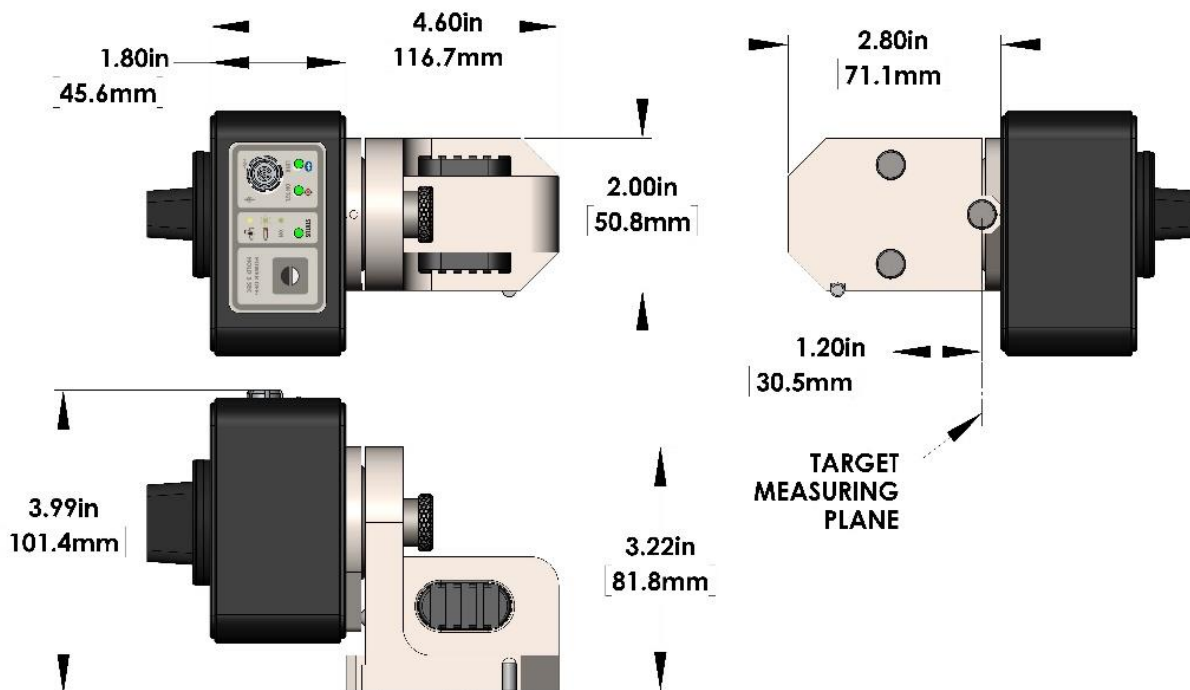

Figure 12 - A-1297-SP Measuring Base - Dimensions

A-703SP-SE-A/B/C/D Target Straight-Edges and Rulers

Used with the A-703SP-LM Surface-Plate Mounting Fixture (see **Figure 8**) as a guide for the T-1297 Target to take flatness data for each line segment. They come in the following sizes:

- A-703SP-SE-A Target Straight-Edge and Ruler – 18 in. (457 mm)
- A-703SP-SE-B Target Straight-Edge and Ruler – 36 in. (914 mm)
- A-703SP-SE-C Target Straight-Edge and Ruler – 54 in. (1,373 mm) – 2 pieces
- A-703SP-SE-D Target Straight-Edge and Ruler – 72 in. (1,829 mm) - 2 pieces
- A-703SP-SE-D-EXT-A 18 in. (457 mm) Target Straight-Edge Extension and Ruler for 72-90 in. (1.8-2.3 m) lengths
- A-703SP-SE-D-EXT-B 18 in. (457 mm) Target Straight-Edge Extension and Ruler for 90-108 in. (2.3-2.7 m) lengths
- A-703SP-SE-D-EXT-C 18 in. (457 mm) Target Straight-Edge Extension and Ruler for 108-126 in. (2.7-3.2 m) lengths

For the 54 & 72-in straight edge and the add-on extensions, they must be assembled as shown in **Figure 13** To assemble the pieces:

1. Screw in the mounting screws but leave them loose.
2. Place the scale side of each straight edge length down on the surface plate to align the straight edge pieces and make them straight.
3. Tighten the screws very tight to ensure the straight edge stays straight.
4. Add the GPR-RB Reinforcement Bar to the top of the straight edge to make it rigid. Do NOT overtighten the bolts. Just a light tightening is fine. Over-tightening may cause the straight edge to bow up, which can cause the rubber feet to fail to make contact with the surface plate.

Note: If the rubber feet come out, use Loctite 496 Glue to reinstall them. The kit should include extra rubber feet.

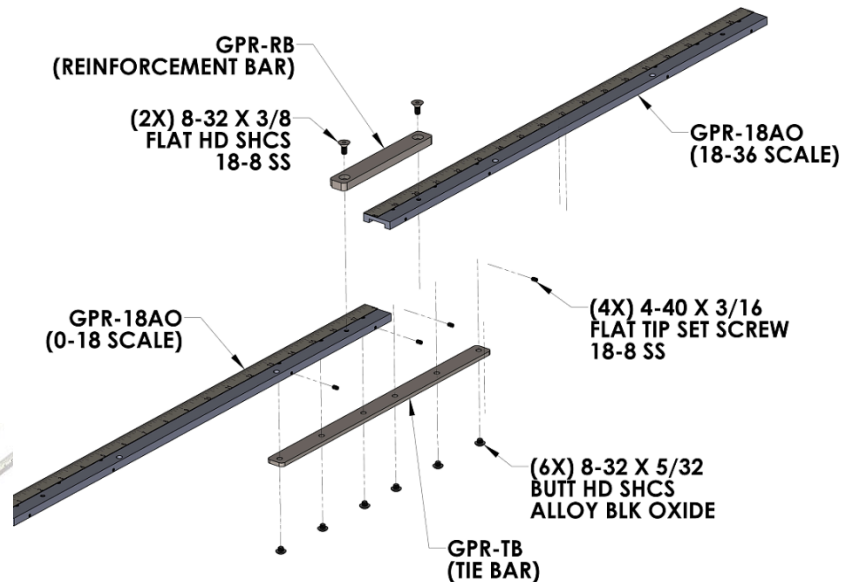

Figure 13 - A-703SP-SE-EXT-A/B Target Straight-Edge



Figure 14 - A-703SP-SE-A/B/C/D Target Straight-Edges and Rulers

Selecting Straight Edge Length

To select the length of the straight edge, use the table below to see which length to use. It is recommended that you select the straight-edge length that is less than 1.5 times the Grid Line Dimension, which ensures the best stability for the bar. For example, for the 18x18 plate, use the 18 in. straight edge for the sides and midpoint segments and the 36 in. straight edge for the diagonals.

We recommend that you assemble the longer straight edges (see above) before starting the alignment checks. This allows you to easily swap in a longer or shorter bar as needed for each segment and speeds up the calibration process.

Here are some definitions for the table:

- *Plate Size* – this is the nominal dimensions of the plate from edge to edge.
- *Diag Bar Increments* – this is the total number of 18-in. increments needed for the straight edge.
- *Longest Bar* – this is the longest bar that is needed for the longest line segment (the diagonal).
- *Grid Line Dimensions* – this is the length of the plate side minus 2 x the border width. This represents the total length needed for the measurements for that line segment.
- *Diag Angle* – this is the angle of the diagonal relative to the edges and is generally not needed for a measurement but is for informational purposes.

Note - if you use a straight edge that is too long for the plate, it will not be stable and may lead to errors.

Plate Size			Diag Bar Increments	Longest Bar	Grid Line Dimensions [(Length/Width - (Border*2))]			
Width	Length	Diag			Width	Length	Diag	Diag Angle
12	12	17.0	1.0	18.0	9.0	9.0	12.7	45.0
12	18	21.6	1.0	18.0	9.0	15.0	17.5	31.0
18	18	25.5	2.0	36.0	15.0	15.0	21.2	45.0
18	24	30.0	2.0	36.0	15.0	21.0	25.8	35.5
24	24	33.9	2.0	36.0	21.0	21.0	29.7	45.0
24	36	43.3	3.0	54.0	21.0	33.0	39.1	32.5
24	48	53.7	3.0	54.0	21.0	45.0	49.7	25.0
36	36	50.9	3.0	54.0	33.0	33.0	46.7	45.0
36	48	60.0	4.0	72.0	33.0	45.0	55.8	36.3
36	60	70.0	4.0	72.0	33.0	57.0	65.9	30.1
36	72	80.5	5.0	90.0	33.0	69.0	76.5	25.6
48	48	67.9	4.0	72.0	45.0	45.0	63.6	45.0
48	60	76.8	5.0	90.0	45.0	57.0	72.6	38.3
48	72	86.5	5.0	90.0	45.0	69.0	82.4	33.1
48	96	107.3	6.0	108.0	45.0	93.0	103.3	25.8
48	120	129.2	8.0	144.0	45.0	117.0	125.4	21.0
60	120	134.2	8.0	144.0	57.0	117.0	130.1	26.0
72	96	120.0	7.0	126.0	69.0	93.0	115.8	36.6
72	144	161.0	9.0	162.0	69.0	141.0	157.0	26.1

Preparing for an Alignment

There are several preparations that need to be made before beginning a measurement or alignment process. Ensure that accurate records are kept for all procedures.

Cleaning the Plate

For accurate calibration results is highly important to clean the surface plate prior to starting the calibration check. Use approved surfaced plate cleaners and cloths to remove all dust and dirt (see **Figure 15** Relative Particle Sizes). If you are trying to calibrate a 36x36 in. plate to a Grade A spec, the flatness requirement is 300 μ in. or 8 μ m (microns). As you can see a few grains of dust (4 microns) on your plate and this eats up half of the Grade A tolerance and can significantly impact the flatness data! Run your hand over the plate to feel for dust and make sure it's ready to check the flatness. We also recommend using a cloth to wipe each measurement line before taking the data. Also, frequent wiping of the bottom of the target base is important to keep dust off of it.

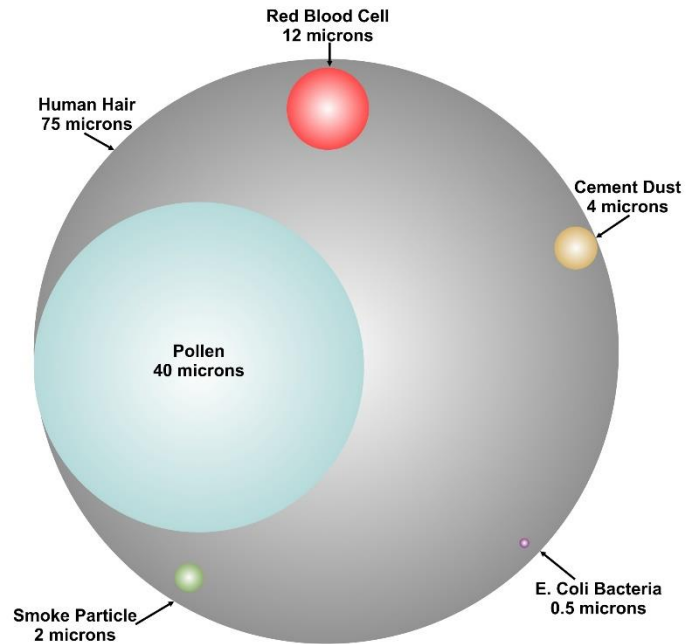

Figure 15 - Relative Particle Sizes

Maintenance and Cleaning of L-703SP & T-1297

The windows on the T-1297 target should be clean and free from dirt, thumbprints, and other smudges. Clean the window with alcohol wipes or a Q-tip soaked in alcohol. Always wipe in the same direction. Do **not** wipe back and forth.

The same applies to the L-703SP Laser Window. If you see a reflection on the lens window on the laser (see **Figure 16**), which means it is contaminated and needs to be cleaned.

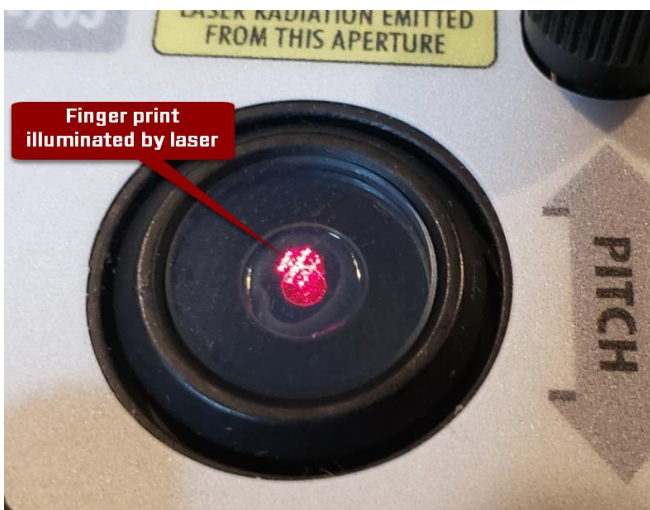

Figure 16 - Dirty vs. Clean Laser Window Example

Target Calibration

The T-1297 Targets are calibrated and the calibration factors are stored inside the target, so there is no need to upload calibration factors into Plane6.

Important Tips for Taking Data with the L-703SP

1. Do Not Touch L-703S-LM During Measurement – After positioning the laser fixture and straight edge, it is VERY important to NOT touch the laser fixture during the measurement of any of the lines. This can cause the fixture to bend, which will move the laser beam and cause additional uncertainty into the measurement.



2. Wear gloves! - It is very important to note that wearing thin gloves to insulate the heat from your hands is an important good practice when handling the L-703SP-LM Laser Fixture. When you hold the L-703SP-LM in your hand, it will warm the metal, causing it to grow thermally, which will happen remarkably fast – in 1 second! This is due to a small microgrowth in the metal upright, which can cause an angular change in the mounting surface, tilting the laser, which can turn into a significant change in the measurement value when the target is located several feet away.
3. Hold the L-703SP-LM Fixture at the Base – It is best practice to hold the L-703S-LM Fixture at the base of the upright. See the image. This will limit the amount of bending in the fixture when moving from line to line and the fixture will stabilize faster.
4. Pause before Taking Data - We recommend waiting between 30-45 seconds after setting down the fixture before taking data for a new measurement line. This gives the fixture time to settle down and stabilize. Of course, if the plate being measured is a B-grade plate, then these precautions are less important and, in the interest of time, can be set aside.
5. Wipe the Surface before Taking Data for Each Line Segment – Use the plate cleaning cloth to wipe the line segment before taking data for the line. This will capture any dust that has fallen on the plate while you have been taking data for the other lines.
6. Hold Your Breath When Positioning the Target – This is not a joke! When recording data with the T-1297 Target, it is important to hold your breath while you are positioning the Target on the measurement point. This is because it is normal to exhale when bending over, and when you are lining up the target, you must bend over it to see the scale, causing you to exhale. Well, believe it or not, the warmth from your breath will create additional air turbulence and increase the variability in the measurements. We found in our testing that this can add more variability if you do not control your breathing!

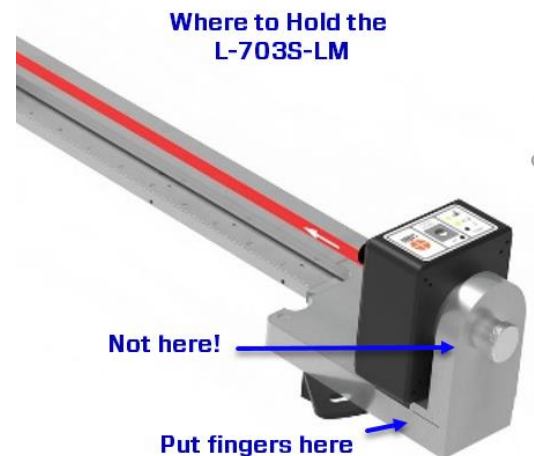

Plane6 Surface Plate Calibration Software - System Requirements

- Physical memory (RAM): 8 GB recommended for Win10 & 11
- Processor: Intel Pentium4 or later version or AMD equivalent, 1.3 GHz minimum speed
- Available Hard Drive space: 20 GB minimum
- Video Resolution: 1366 x 768 minimum (32-bit color) with hardware acceleration and dedicated video memory.
- Windows 8/10/11 professional editions.

The following Microsoft Windows operating systems have *not* been tested and are **not supported** with Plane6:

- Windows 7 Ultimate (N, & x86), Windows 7 Ultimate N, Windows 7 Enterprise (N, x64 & x86), Windows 7 Enterprise (N & x64)
- Windows 7 Home Premium (x64 & x86),

The following Microsoft Windows operating systems are **not recommended** for use with Plane6:

Windows 7 Home Basic, Windows Vista (all version releases), Windows XP (all version releases).

Before installing Plane6, ensure that your computer has the latest Windows Service Pack and critical updates. To find security updates, visit www.windowsupdates.com.

In addition, to read this Plane6 Surface Plate Calibration manual PDF file on your laptop, it is necessary to install Adobe Reader/Acrobat or an equivalent PDF reader program. Adobe Reader can be downloaded for free from: [Download Adobe Acrobat Reader: Free PDF viewer](#).



Installing Plane6

1. Insert the USB flash drive provided into the USB port on the laptop or tablet PC.
2. If your system is configured to do so, the AutoPlay window displays. Click **Open folder to view files**.
3. If the AutoPlay window does not display, click **Start>Run**. Click **Browse>My Computer** and select the USB flash drive.
Note: *.NET 4.0 framework must be installed– see Page 55 if you are unsure if this has been installed.*
4. Click **setup.exe** to begin the Plane6 installation.



Getting Started with Plane6

Hamar Product Registration

After a Hamar product is installed and when the program is run for the first time, the user is prompted to enter the Product Registration Code (see **Figure 17**). To obtain the Product Registration Code, send the **PC ID Code** displayed on the screen to Hamar Laser Support (Support@hamarlaser.com). A Hamar representative will issue a Product Registration Code via email to complete the registration process (see **Figure 18**).

Enter the Product Registration Code and click **Register Product**. The product is now registered.



Figure 17 - Product Registration Screen

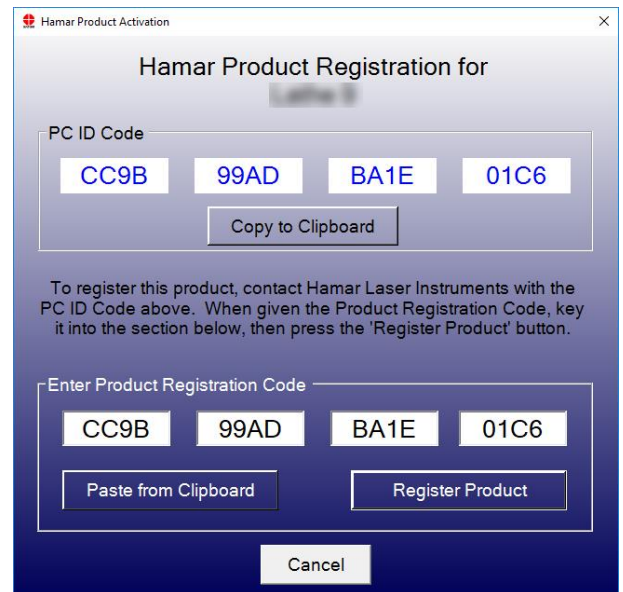

Figure 18 - Enter Product Registration Code

To begin using Plane6, double-click the Plane6 icon on your desktop or select the program from the Windows Start Menu. The initialization screen displays, providing the number of the current software version.

Creating a New Project File or Opening an Existing Project File

When Plane6 opens, the **Project Selection** screen displays.

Recent Projects – This will list the most recent projects that were saved.

Open Project – select one of the recently saved projects and click **Open Project** to open the project. You can also double-click the filename to open it.

New Project – click here to enter a filename and create a new project.

Browse – Click here to open the Windows File Open dialog box and browse for a saved file, either from another folder or from a USB drive.

Exit Plane6 – this closes Plane6.

Note: This screen can also be accessed by clicking **Open Project** from the **File** menu.

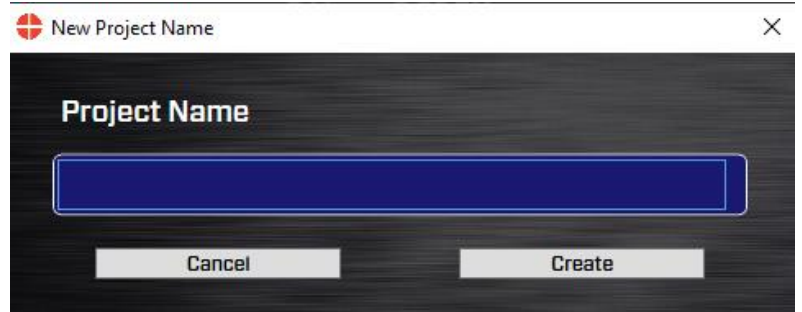
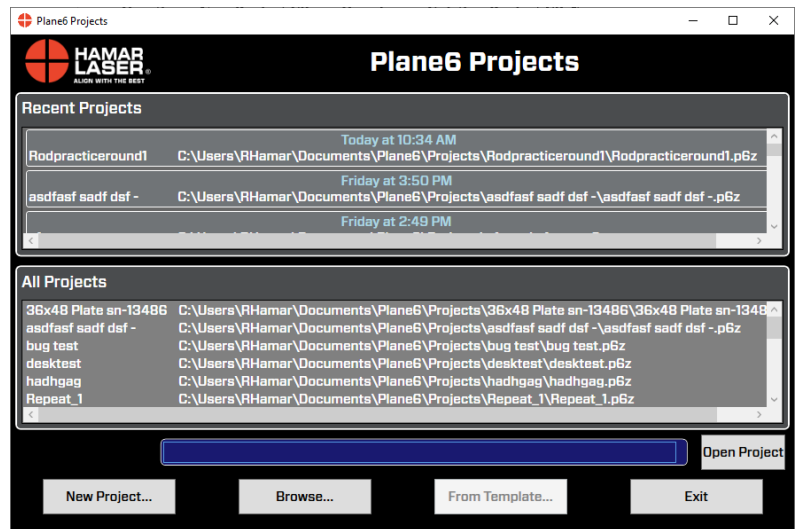

File Menu

New Project – see above

Open Existing Project – same as above

Save Project – saves the project.

Save Project As –allows you to save an existing project as a new project. It keeps all the data from the existing project.

Save Project As Template –allows you to save an existing project as a new project. It keeps only the information entered in Step 1. All the data from Step 2 is erased.

Exit – exits Plane6 and if the project has not been saved will prompt you to save it.

File Location

Files are saved in the *Documents/Plane6/Projects* folder.

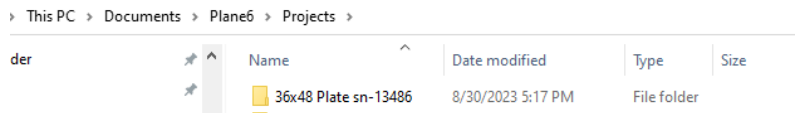
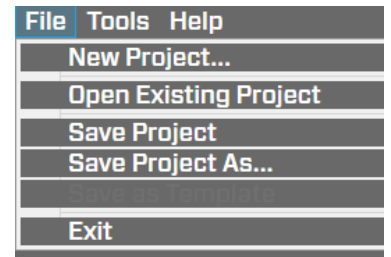

Each project is saved into a dedicated folder in the Projects folder that you specified in the New File dialog box.

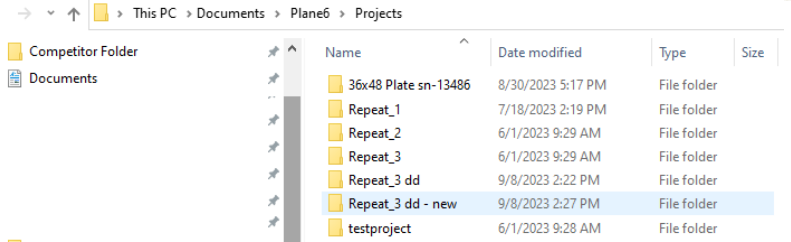

File Structure

In each Plane6 folder, there are 2 data files.

- The *****.p6z** file contains all the data taken during the session.
- The ***.p6z.backup*** are backup files recorded during each session you save data.

The data format for these files is XML but it can be exported to a CSV file by clicking on the Tools menu. The file can be opened in Notepad and viewed there. All data is recorded in microns. Divide all values by 1000 to get millimeters.

Warning! Do not delete or modify the P6z files in these folders as Plane6 will be unable to open the project.

Converting Raw Data Values in CSV files to Inches or Millimeters

The values stored in the CSV file correspond to the units chosen in Preferences, either μin or μm .

- To get inches, divide the microinch value by 1,000,000:
- To get mm's, divide the micron value by 1000

Name	Date modified	Type	Size
36x48 Plate sn-13486.p6z	8/30/2023 5:17 PM	P6Z File	8 KB
36x48 Plate sn-13486.p6z.backup1	8/28/2023 10:29 AM	BACKUP1 File	8 KB
36x48 Plate sn-13486.p6z.backup2	8/24/2023 5:58 PM	BACKUP2 File	8 KB
36x48 Plate sn-13486.p6z.backup3	8/24/2023 5:25 PM	BACKUP3 File	8 KB

```

36x48 Plate sn-13486.p6z - Notepad
File Edit Format View Help
<?xml version="1.0" encoding="utf-8"?>
<!--Copyright 2012-2023 Hamar Laser Instruments, Inc. All rights reserved.-->
<?Plane6 preferences?>
<project>
  <SelectedTargetGuid></SelectedTargetGuid>
  <ProjectFileVersion>1.2.0</ProjectFileVersion>
  <FileWriteTime>8/30/2023 5:17:06 PM</FileWriteTime>
  <ProjectName>36x48 Plate sn-13486</ProjectName>
  <ProjectDescription></ProjectDescription>
  <Notes></Notes>
  <TechnicianName></TechnicianName>
  <ContactInfo></ContactInfo>
  <RecordingDate>8/30/2023</RecordingDate>
  <RecordingTime>4:43 PM</RecordingTime>
  <ComputerName>LAPTOP-Q1330HIU</ComputerName>
  <ProjectName>36x48 Plate sn-13486</ProjectName>
  <ApplyOffsets_Target1>false</ApplyOffsets_Target1>
  <CalculatedOffset_Target1_Microns>0</CalculatedOffset_Target1_Microns>
  <ApplyOffsets_Target2>false</ApplyOffsets_Target2>
  <CalculatedOffset_Target2_Microns>0</CalculatedOffset_Target2_Microns>
  <ApplyOffsets_Target3>false</ApplyOffsets_Target3>
  <CalculatedOffset_Target3_Microns>0</CalculatedOffset_Target3_Microns>
  <ApplyOffsets_Target4>false</ApplyOffsets_Target4>
  <CalculatedOffset_Target4_Microns>0</CalculatedOffset_Target4_Microns>
  <Surface_BOTTOM_ShapeType>MOODY_RECTANGLE</Surface_BOTTOM_ShapeType>
  <Surface_BOTTOM_SurfaceName>BOTTOM</Surface_BOTTOM_SurfaceName>
  <Surface_BOTTOM_ToleranceMicrons>0</Surface_BOTTOM_ToleranceMicrons>
  <Surface_BOTTOM_MoodyCenterToleranceMicrons>2.53999999999726</Surface_BOTTOM_MoodyCenterToleranceMicrons>
  <Surface_BOTTOM_ShapeParameterCount>11</Surface_BOTTOM_ShapeParameterCount>
  <Surface_BOTTOM_Shape_PARAM_Border_Microns>38100</Surface_BOTTOM_Shape_PARAM_Border_Microns>
  <Surface_BOTTOM_Shape_PARAM_Rectangle_HeightMicrons>914400</Surface_BOTTOM_Shape_PARAM_Rectangle_HeightMicrons>
  <Surface_BOTTOM_Shape_PARAM_Rectangle_WidthMicrons>914400</Surface_BOTTOM_Shape_PARAM_Rectangle_WidthMicrons>
  <Surface_BOTTOM_Shape_PARAM_X_Line_Points>7</Surface_BOTTOM_Shape_PARAM_X_Line_Points>
  <Surface_BOTTOM_Shape_PARAM_Y_Line_Points>7</Surface_BOTTOM_Shape_PARAM_Y_Line_Points>
  <Surface_BOTTOM_Shape_PARAM_Diagonal_Line_Points>7</Surface_BOTTOM_Shape_PARAM_Diagonal_Line_Points>
  <Surface_BOTTOM_Shape_PARAM_PlateGrade>A4</Surface_BOTTOM_Shape_PARAM_PlateGrade>
  <Surface_BOTTOM_Shape_PARAM_LabelLocationAB</Surface_BOTTOM_Shape_PARAM_LabelLocation>
  <Surface_BOTTOM_Shape_PARAM_PlateSerialNumber></Surface_BOTTOM_Shape_PARAM_PlateSerialNumber>
  <Surface_BOTTOM_Shape_PARAM_TemperatureTop></Surface_BOTTOM_Shape_PARAM_TemperatureTop>
  <Surface_BOTTOM_Shape_PARAM_TemperatureBottom></Surface_BOTTOM_Shape_PARAM_TemperatureBottom>
  <Surface_BOTTOM_DatepointCount>56</Surface_BOTTOM_DatepointCount>
  <Surface_BOTTOM_DataPoint_0>AC[0]</Surface_BOTTOM_DataPoint_0>
  <Surface_BOTTOM_DataPoint_1>AC[1]</Surface_BOTTOM_DataPoint_1>
  <Surface_BOTTOM_DataPoint_2>AC[2]</Surface_BOTTOM_DataPoint_2>
  <Surface_BOTTOM_DataPoint_3>AC[3]</Surface_BOTTOM_DataPoint_3>
  <Surface_BOTTOM_DataPoint_4>AC[4]</Surface_BOTTOM_DataPoint_4>
  <Surface_BOTTOM_DataPoint_5>AC[5]</Surface_BOTTOM_DataPoint_5>
  <Surface_BOTTOM_DataPoint_6>AC[6]</Surface_BOTTOM_DataPoint_6>
  
```

Restoring File Backups

To restore older version backup:

- 1) Rename original file to something else, or delete it
- 2) Rename backup by removing the ".backupn" part. In the example, change *36x48 Plate sn-13486.p6z.backup1* to *36x48 Plate sn-13486.p6z*

Name	Date modified	Type	Size
36x48 Plate sn-13486.p6z	8/30/2023 5:17 PM	P6Z File	8 KB
36x48 Plate sn-13486.p6z.backup1	8/28/2023 10:29 AM	BACKUP1 File	8 KB
36x48 Plate sn-13486.p6z.backup2	8/24/2023 5:58 PM	BACKUP2 File	8 KB
36x48 Plate sn-13486.p6z.backup3	8/24/2023 5:25 PM	BACKUP3 File	8 KB

Plane6 Software – Summary of Main Screens

Step 1: Set Up Plane6

Enter the horizontal and vertical dimension of the plate and the border width from the edge of the plate to the measuring line. Then select the number of points you want to measure for the horizontal, vertical and diagonal lines. Next select the plate grade enter the plate serial number and top and bottom temperature (if measured).

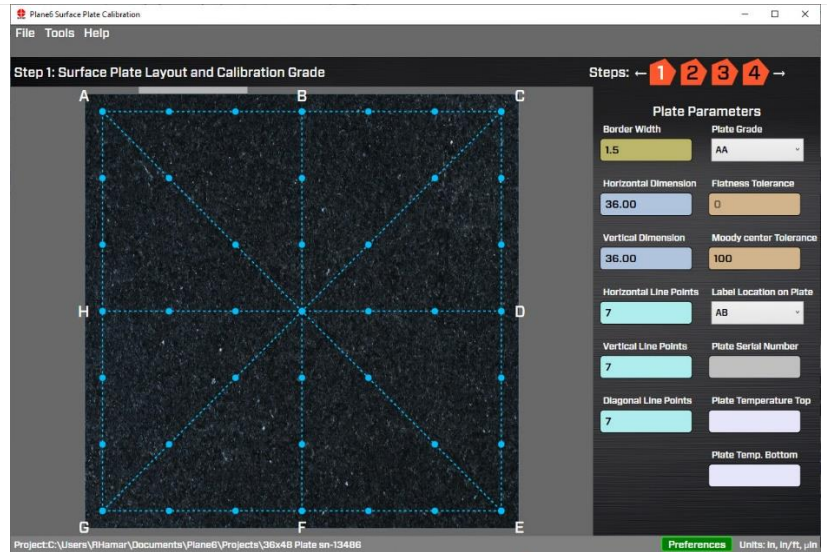

Figure 19 - Plane6 - Step 1 Dimensions & Tolerances

Step 2: Data Collection

This is the main data recording screen. It features a 2-axis, real-time data display, the layout for the plate, the measurement points and distances. It guides the user through the sequence of data taking for the 8 line segments in the Moody Method for calibrating surface plates.

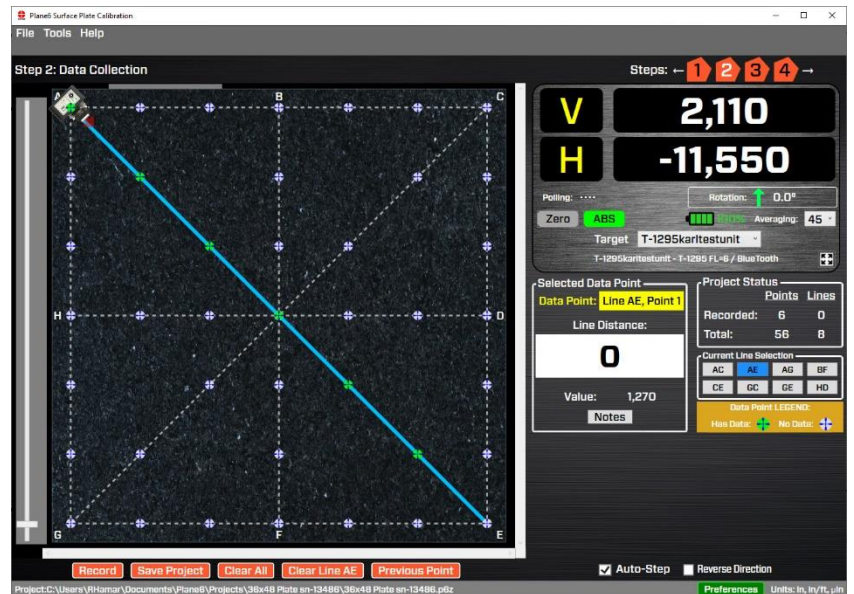

Figure 20 - Plane6 - Step 2: Data Collection

Step 3: Results -

After recording the data, click on Step 3 to view the overall flatness results and whether it is in tolerance or out. You can also view the data for each line segment and a 3d graph of the alignment.

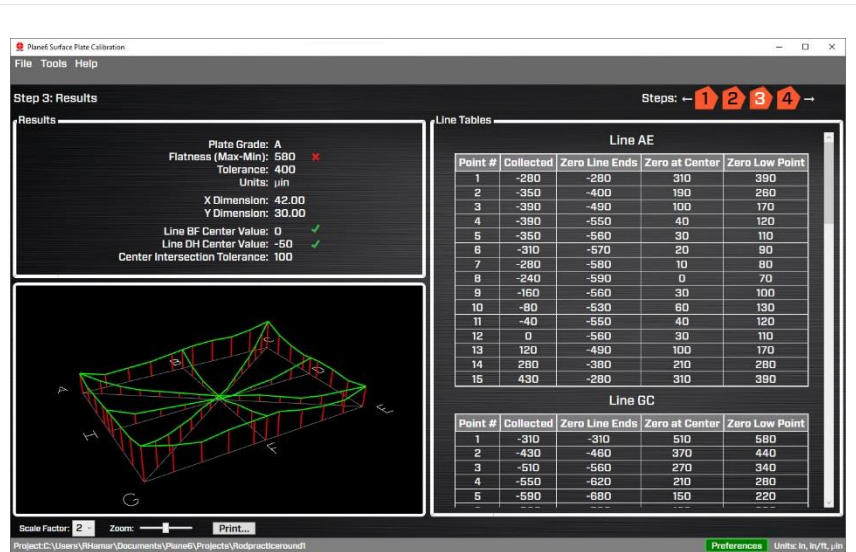

Figure 21 - Plane6 - Step 3: Results

Step 4: 3D Graph

In Step 4, you can view and adjustable, 3D graph of the alignment. Rotate and zoom in to see the results for each line segment plotted on the graph.

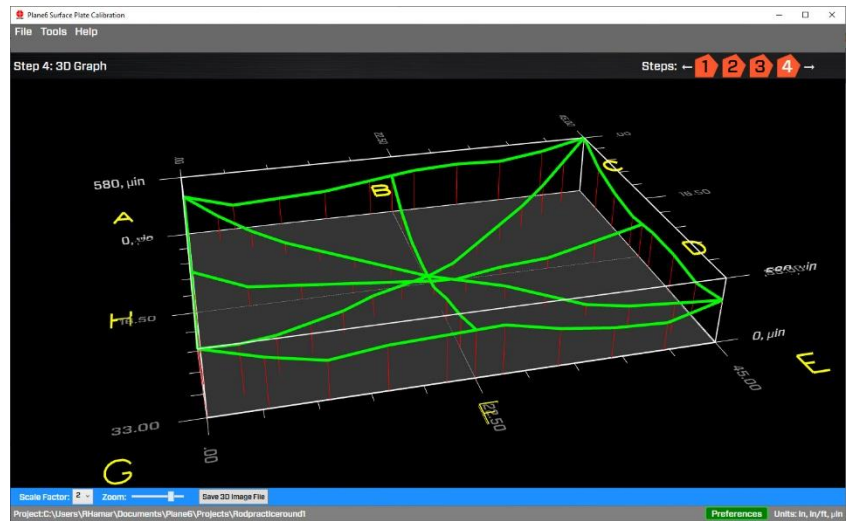

Figure 22 - Plane6 - Step 4: 3D Graph

Plane6 Screens - File Menus

The File Menu

New Project – see above

Open Existing Project – same as above

Save Project – saves the project.

Save Project As –allows you to save an existing project as a new project. It keeps all the data from the existing project.

Save Project As Template –allows you to save an existing project as a new project. It keeps only the information entered in Step 1. All the data from Step 2 is erased.

Exit – exits Plane6 and if the project has not been saved will prompt you to save it.

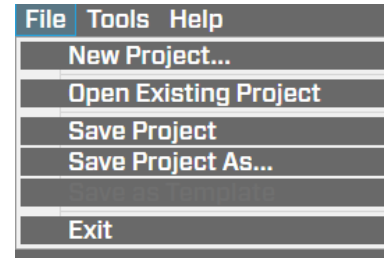

The Tools Menu

Preferences - Opens the Preferences window to change units, decimals, target type, etc.

Preferences – Change data display units, resolution, target setup and typical setup items. See more details below.

Export Line Data to CSV File – Exports data in a CSV format to easy importing into Excel. After clicking on this item, you will be prompted to enter a filename for the project. It uses the existing filename by default. After saving the file, use Excel to open the file and the data will be in there. The file contains the raw date from the table and does not display the results.

Show Line Dimensions – Opens a window showing the number of measurement points, the line distance for each point on the line segment for the horizontal lines, vertical lines and diagonal lines.

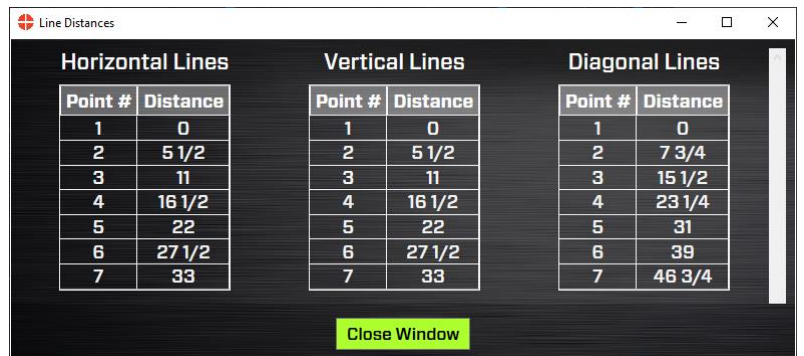
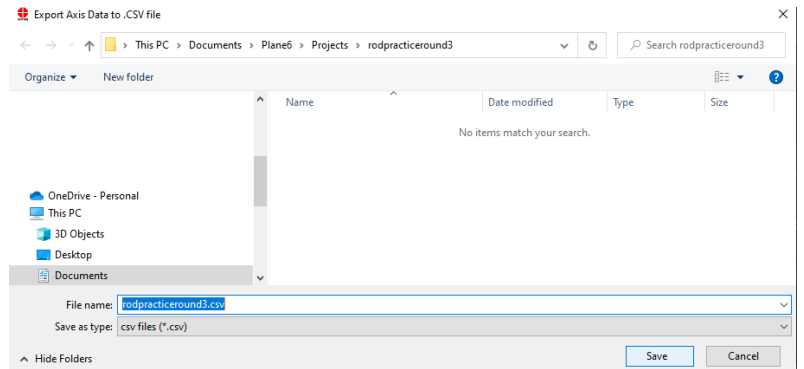
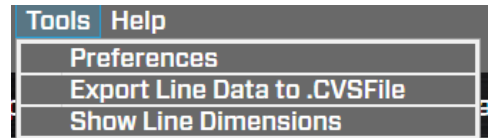

Figure 23 - Plane6 Show Line Dimensions window

The Help Menu.

About This Program - Usual info about the program.

User Manual - Opens a PDF of the manual.

Navigating Plane6 with the Status Bar

Software Steps

In the upper right part of the screens is the Navigation Bar. It lists the number of steps in the software along with arrows to move to the left or the right. You can either click the arrow to move back or forward to the previous or next step or click on any step to straight to the page.



Plane6 Screens - Preferences

Click **Preferences** to open a window to change Plane6 settings. You can also click on the Preferences button in the lower right side of each screen in Plane6.

Note: If you are installing the software yourself, you will need to go to **Enter Target Info** (see **Page 27**) and follow the procedure to enter the target serial number and calibration factors.

Navigation – Use the Navigation button to go to a particular section in Preferences. You can also use the scroll bar to move the scrollable section up and down.



Project Information

Enter a project description, company contact information and notes that will be displayed in the reports here.



Units

Select **Imperial** (in.) or **Metric** (mm) and units for the project. Check on the **µin** checkbox to see the units in *microrches*, or **µm** to see the units in *microns*.

If you prefer normal digits, then select the number of digits to show in the display.

For the line dimensions, you can also select the fraction rounding increment and Plane6 will round the fraction up or down to the selected value. For example, if "1/4" is selected and the next point dimension is 5 3/16, then Plane6 will display 5 1/4 as the dimension for the next point. You can also choose a decimal in the display.

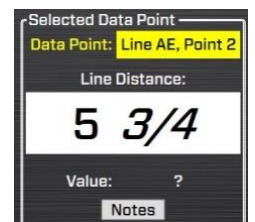
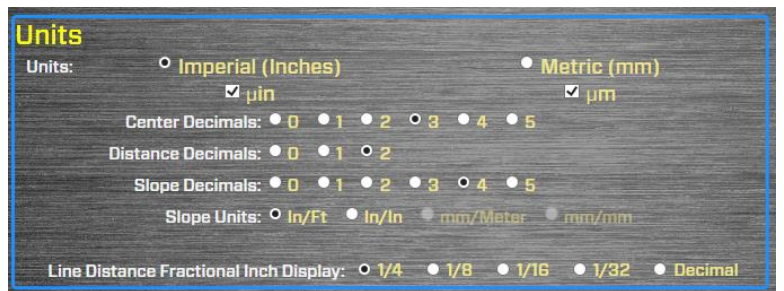

Targets

Target settings

Vertical & Horizontal Tolerance (\pm) – this is a display tolerance for Step 2 that changes the display background color to orange if these tolerances are exceeded. The default is:

Vertical: \pm .010 in. (10,000 μ m.)

Horizontal: \pm .030 in. (30,000 μ m.)

Vertical: \pm 0.25 mm (250 μ m)

Horizontal: \pm 0.75 mm (750 μ m)

If the display values are higher than these, the values will start to become slightly less accurate. If you are working on a B-grade plate, then these values can be exceeded without an issue.

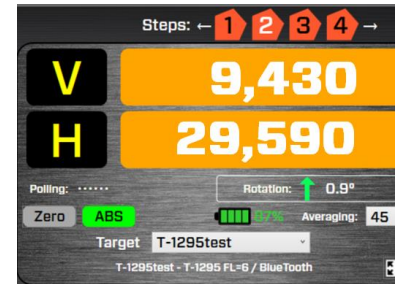
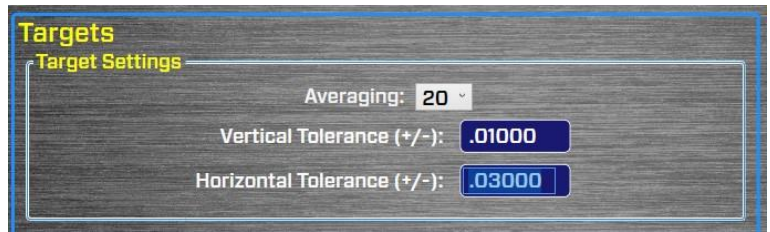

Defined Targets

This is a list of T-1297 Targets (or other similar targets) that have been set up in Plane6.

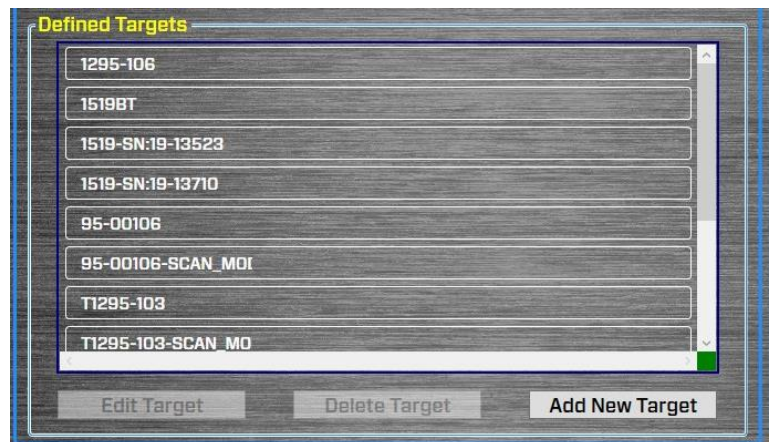

This list will show up in the dropdown menu in Step 2.

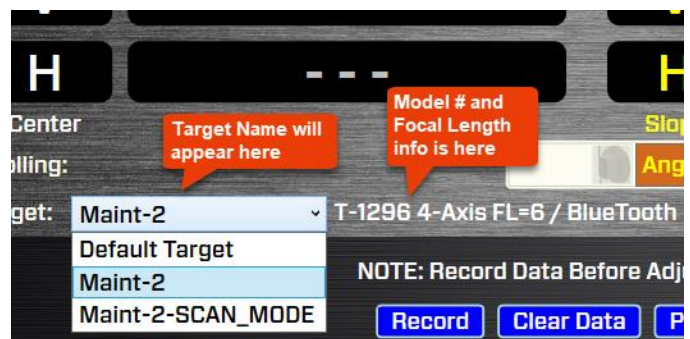

Targets - Setup Procedure

When you buy a new system and laptop from HLI, the target setup is already pre-configured into Plane 6. However, if you are installing Plane6 on your laptop, then you must follow this procedure to set up the target.

1. Click the **Target** button.

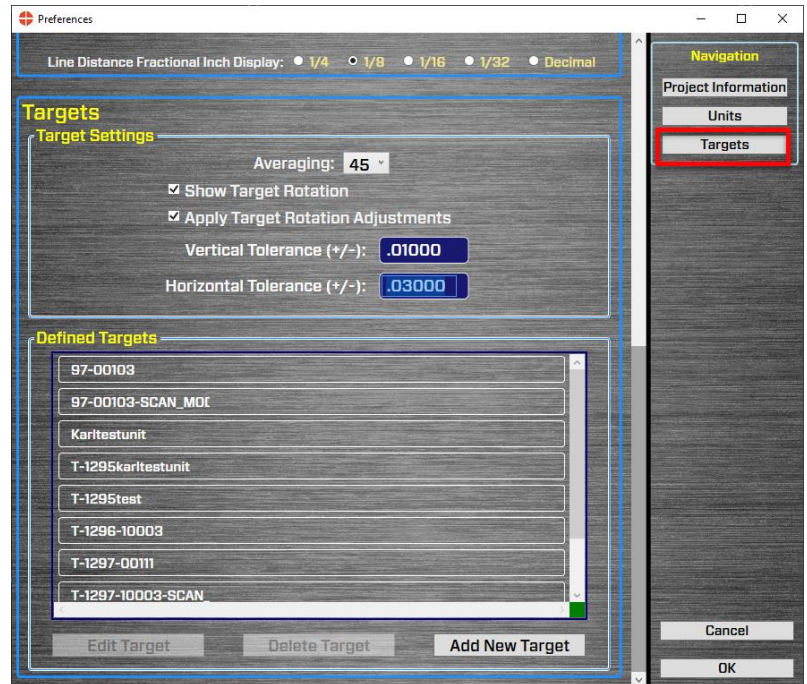

2. Click **Add New Target** to specify and set up a target type and computer interface if needed. There will be a dropdown list of target types supported by Plane6. Pick the T-1297 target type by clicking on it.

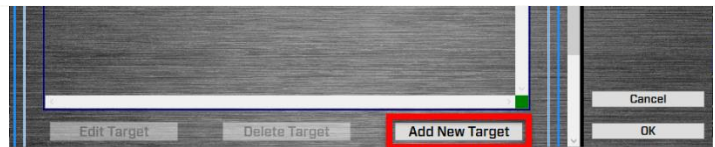

3. **Select Target Type – T-1297 Targets 3-Axis Mode**

To choose the T-1297 targets, select the target number with “3-Axis Mode”. Do not select “Scan Mode”.

Note - the Scan Mode will automatically be added as a target type for each T-1297 selected. Scan Mode is needed with the L-702SP or L-730/740 Series Lasers for a different application.



- Target Name.** Enter a “nick name” for the target. This name will show up in the Target area on the data displays. The target part number and focal length are automatically displayed by Plane6.

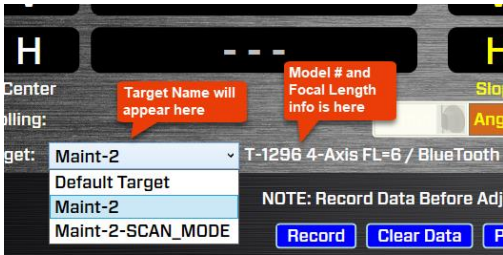

- Serial Number and Calibration Date** – enter the serial number and calibration date (supplied with the system)
- Scan for Bluetooth Targets** - You will need to pair the targets with the laptop - see **Page 7, How to Pair the T-1297 Target’s Bluetooth to a PC.**

After pairing, click on **Scan for Bluetooth Targets** to see if your target has been paired with your PC. Paired targets will display in window (shown right). If your target is not displayed, it will need to be paired.

If it shows up in the list, then click on the serial number and click on **Select Serial Number XXXX** to select the paired target. Then click on **Close Window**.

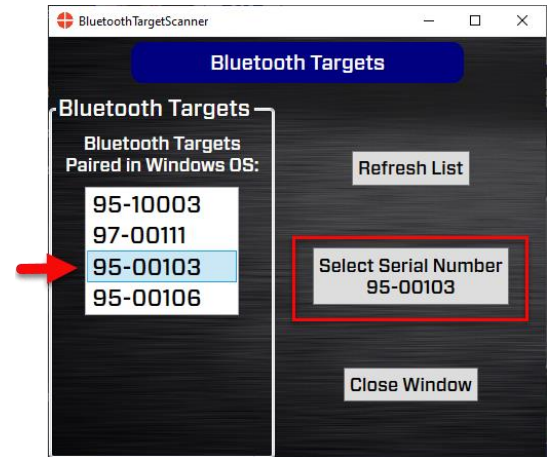
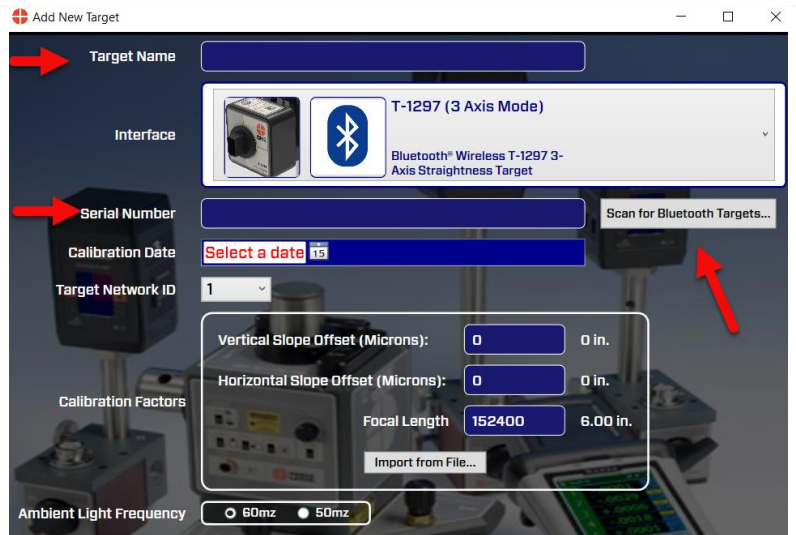

7. Target Network ID

This is needed for our A-1519/1520 Scanning targets and not used in this application.

8. Calibration Factors - Vertical and Horizontal Slope Offsets and Focal Length.

These are correction factors that are used for another application and are not needed for surface plate calibration.

9. **Ambient Light Frequency** – The T-1297 Targets utilize an ambient light correction feature that improves accuracy. This requires that the target be set to the existing electrical frequency. Normally the U.S. is 60 Hz and Asia/Europe is 50 Hz

Note – the target must be turned on and be paired with the PC to change the frequency. Normally this is set at the factory to match the country it is being shipped to.

10. **Defined Targets** - You can set up multiple targets if desired. The target names and modes will appear in the **Defined Targets** area.

To select a target go to **Step 2** and choose from the **Target** dropdown list where up to 10 target setups may be stored.

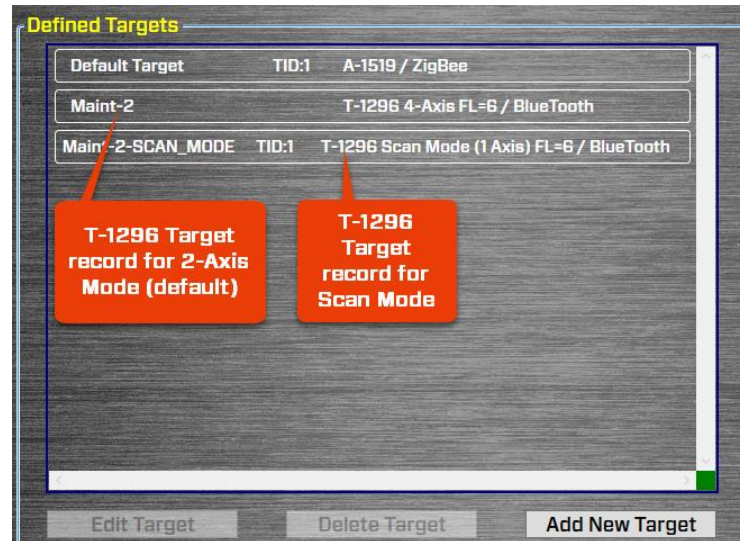
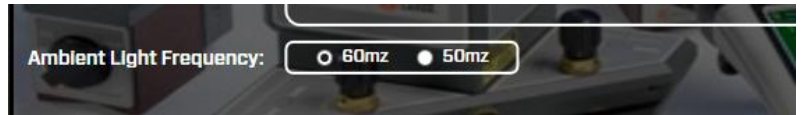
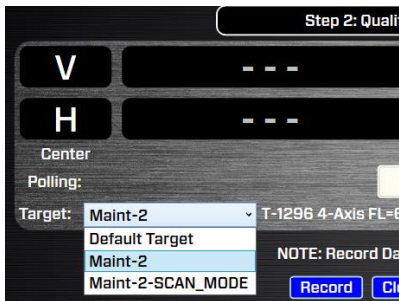

Plane6 Screens - Step 1: Dimensions and Tolerances

Enter the horizontal and vertical dimension of the plate and the border width from the edge of the plate to the measuring line. Then select the number of points you want to measure for the horizontal, vertical and diagonal lines. Next select the plate grade enter the plate serial number and top and bottom temperature (if measured).

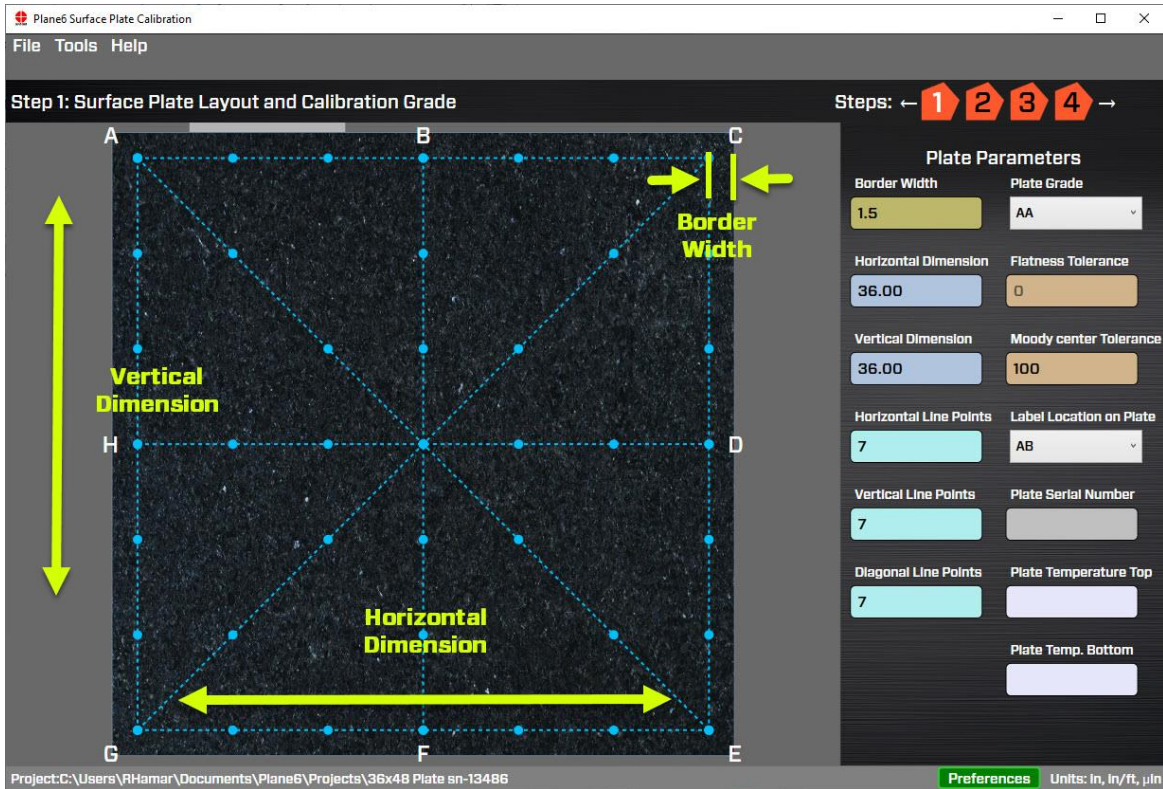

Border Width: Width of the margin between the physical outside edges of the plate and the measurement area. The ANSE spec typically calls for 1.5 in. (33.1 mm) borders pacing.

Horizontal Dimension: Outside horizontal dimension of the physical plate in inches or mm's.

Vertical Dimension: Outside vertical dimension of the physical plate in inches or mm's.

Horizontal/Vertical/Diagonal Line Points: The number of points to be recorded for each of the line types.

Plate Grade: AA, A, B or Custom. The *Flatness Tolerance* is set automatically based on ANSE B89.3.7.2013 standard. If *Custom* is selected, the *Flatness Tolerance* can be manually set.

Flatness Tolerance: This is enabled if *Custom* is selected under *Plate Grade*. This is the overall flatness tolerance for the plate. It is the difference between the highest and lowest measured point. Enter the value and click on any other part of the screen for Plane6 to accept it.

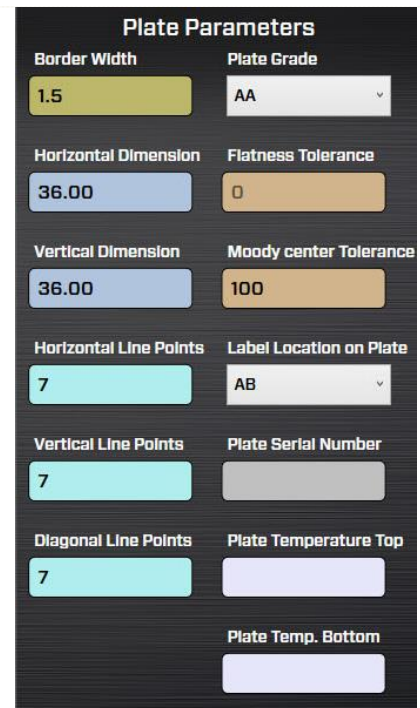

Moody Center Tolerance: As per *Moody Method* procedure, this is the maximum allowed deviation between the intersecting diagonal lines after all point adjustments have been made. If this tolerance is exceeded, it suggests that measurement errors were made, and it suggested that the data be retaken.

Plate Serial Number: Enter the plate's serial number for the report.

Label Location on Plate: Location of the manufacturer's label applied to the plate. The letters correspond to the letters on the plate graphic A...H points as shown above. *AB* means the plate is located between A & B on the plate.



Plate Temperature Top/Bottom: Temperatures for the top and bottom of the plate (if measured) as the flatness data was recorded.

Plate Parameters	
Border Width	Plate Grade
1.5	AA
Horizontal Dimension	Flatness Tolerance
36.00	0
Vertical Dimension	Moody center Tolerance
36.00	100
Horizontal Line Points	Label Location on Plate
7	AB
Vertical Line Points	Plate Serial Number
7	
Diagonal Line Points	Plate Temperature Top
7	
	Plate Temp. Bottom

Plane6 Screens - Step 2: Data Collection

In **Step 2: Data Collection**, the flatness data is recorded. The screen uses a predetermined sequence of the recording of each line segment. When setting up the laser, put should be placed at the point where the target icon is located and pointed in the direction of the arrow (see more information below under L-703SP - How It Works Page 38).

Plane6 will show the dimension on the straight-edge ruler for the next point and will show the line segment and point number that is going to be recorded. After a data point is recorded, the point-location icon will turn green indicating it has recorded data.

After recording the last point for a given line segment, Plane6 will move the target icon to the next line segment which takes the least amount of setup time.

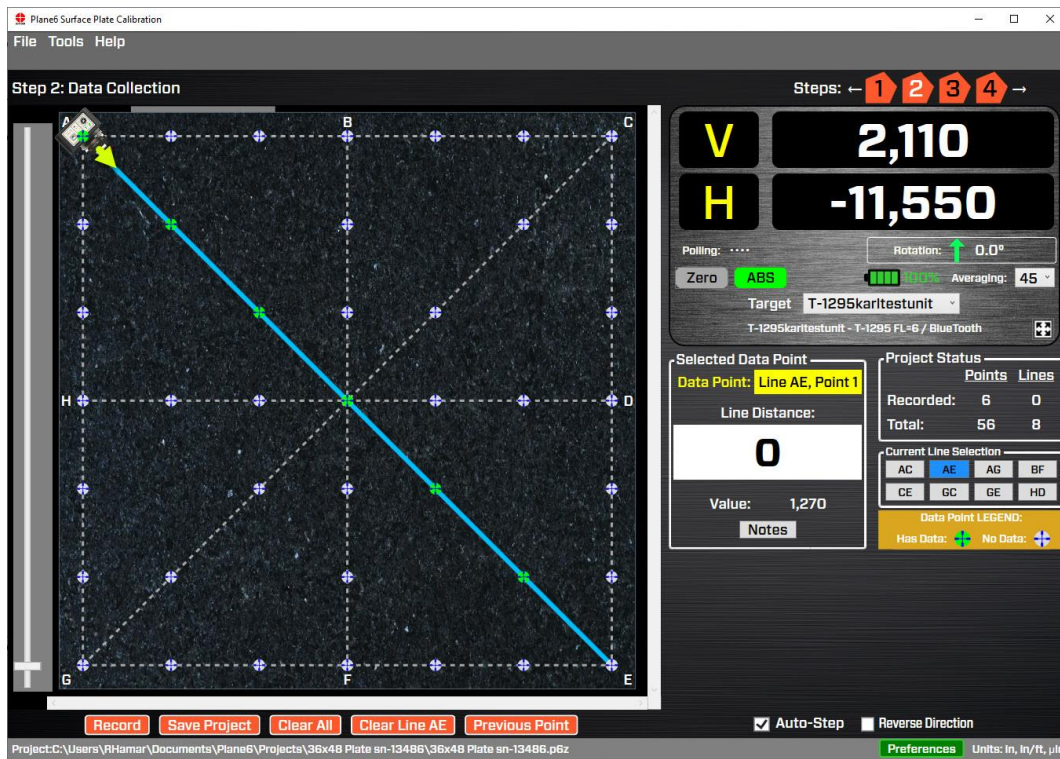

What the Buttons Do

Record – click **Record** or press the spacebar to record the data point. After pressing **Record**, a window will open and display how many samples are being recorded and will close after the sampling is done. The number of samples is changed by changing the *Averaging* in the display area – see below.

Note: when first hitting record, Plane 6 pauses for 2 seconds to let the readings settle. Also, if the laser is blocked during sampling, Plane6 will automatically restart the data taking.

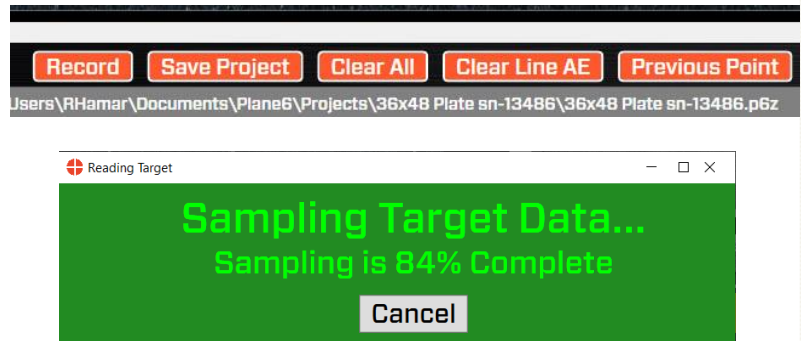

Save Project – click here to save the data already recorded.

Note - Plane6 has an auto-saving feature. See page 19 **Restoring File Backup** to see how to recover data from backups.

Clear All – this clears all the data from all the line segments recorded for the plate.

Clear Line XX – this clears all the data from the line segment currently selected.

Previous Point – this moves the target icon (cursor) to the previously recorded point to re-record it.

Zero – Click here to zero the display. This is generally **not** needed to record the data but may be useful when sampling small areas of the plate.

ABS – Click here to return the data display to the absolute (raw) value display from the target. This is a measure of how far from the PSD sensor's center the laser beam is located.

Normally ABS Mode is used for recording data.

Averaging – enter values from 1 to 500 and this will change the number of samples Plane6 uses to average for each of the values shown in the data displays.

This also changes the amount of sampling the software takes when recording a data point. So a value of 45 means that Plane6 will record 45 target values, average them and record the averaged value as the data value for that point.

Note: *The higher the averaging value, the more noise fluctuations will be dampened out, but also the slower the response time for movements in the laser position. The data updates at ~13 readings per second, so with an averaging value of 26, the data takes about 2 seconds to update after the laser beam position has started moving.*

The recommended starting value for most small-to-medium plates in good environmental conditions is 10 (~2 seconds per point) for A & B grades. If doing AA grade, then up the sampling to 40 (4-5 seconds per point).

Target Battery Icon – displays the estimated remaining battery life of the target. It updates continuously.

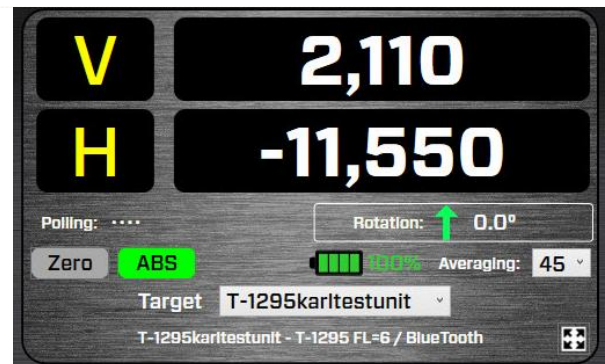

Target – this is the dropdown list of all the targets that have been set up in *Preferences* to allow you to change the target if using your laptop with a different set of laser/target. This is normally not changed unless you are switching laptops and laser/target kits. See page **Targets - Setup Procedure** on Page 26 to add to this list.

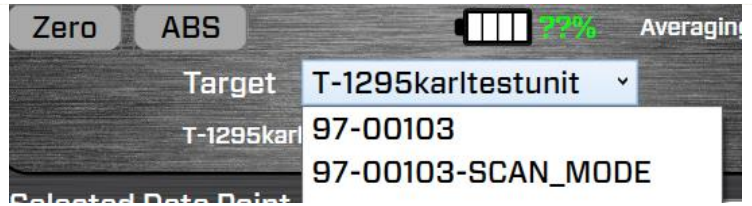

Plane6 Screens - Step 3: Results

When all the data is collected, click on Step 3 icon to bring you to Step 3: Results. This shows the Moody Method calculations to get the overall flatness results.

The results are summarized in the Results Table and the plate-grade tolerance, chosen from Step 1, is applied and a red X or green checkmark is displayed to indicate if the overall flatness is in or out of tolerance.

A graph is also shown giving a snapshot of the flatness data. A more dynamic graphic of the flatness is shown in **Step 4: Graph**.

The data tables for each line segment are also shown along with the various values needed to calculate the overall flatness. The **Zero Low Point** column is the corrected flatness value for that line segment. The zero point is the lowest value of all the sets of data.

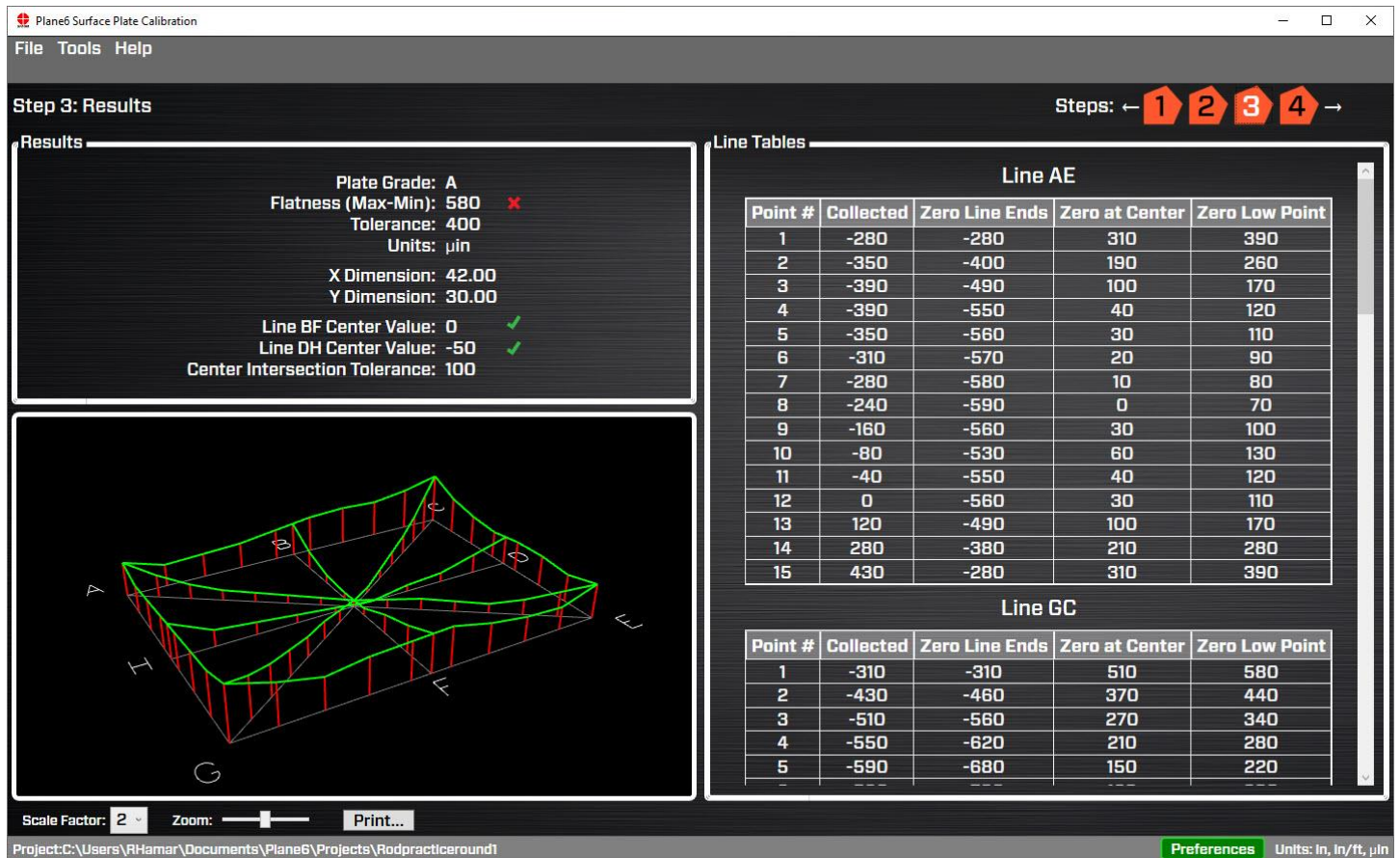

Figure 24 - Plane6 Step 3: Results

Center Line Tolerance Check

Check to make sure both center line value tolerance checks are in tolerance. This means it's a good set of data.

However, if the center value check is out of tolerance, then the B89-3-7_2013 Surface-Plate Standard recommends that the data be retaken. You can either retake the entire plate data or you can first try to retake the data for the line segment that is out of tolerance. In the example below, you would retake the BF line data. As long as this data is taken within a reasonable amount of time from the time the overall plate data was recoded, then this is a valid way to try to correct the out of tolerance condition.

Procedure to retake a line segment.

1. Open the saved file if it's not already opened.
2. Go to Step 2 and select the line segment that is out of tolerance.
3. Setup the laser, laser fixture, straight edge and target as detailed above for the line segment you want to re-shoot.
4. Click on **Clear Line XX** button at the bottom of the screen (in this case the button will say **Clear Line BF**).
5. Retake the data for the line.
6. Go to Step 3 to see if the results are now in tolerance.
7. Save file.

Plate Grade:	A
Measured Flatness (Max-Min):	930 ✘
Tolerance:	400
Units:	$\mu\text{in}/\text{in.}$
X Dimension:	45.00
Y Dimension:	33.00
Line BF Center Value:	160 ✘
Line DH Center Value:	40 ✔
Center Intersection Tolerance:	100

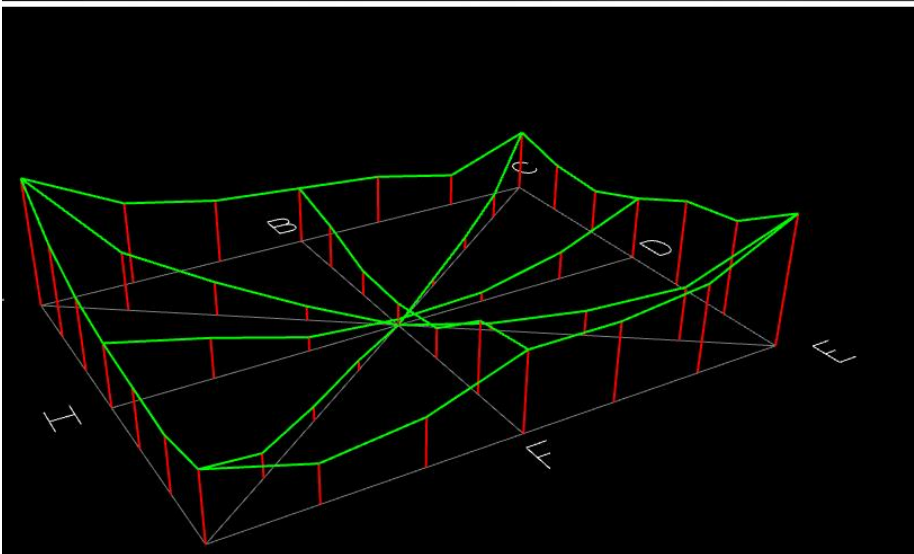

Plane6 Screens - Step 4: Graph

To see a more comprehensive graph of the flatness results, click on Step 4: Graph. This takes you to a user adjustable graph where you can rotate the graph, zoom in and out and adjust the graph to study the results.

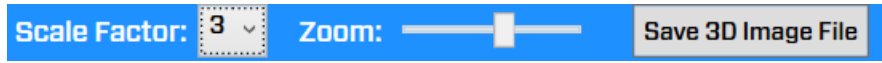

To rotate the graph, use a mouse to click and drag left/right or up/down. To make the elevation of the graph lines larger, click on **Scale Factor**. To zoom in/out on the whole image, slide the bar under **Zoom** or use the scroll.

You can also save the graph as a JPG file by hitting the **Save 3D Image File** button at the bottom of the screen. This saves the screen to a JPG file on your hard drive.

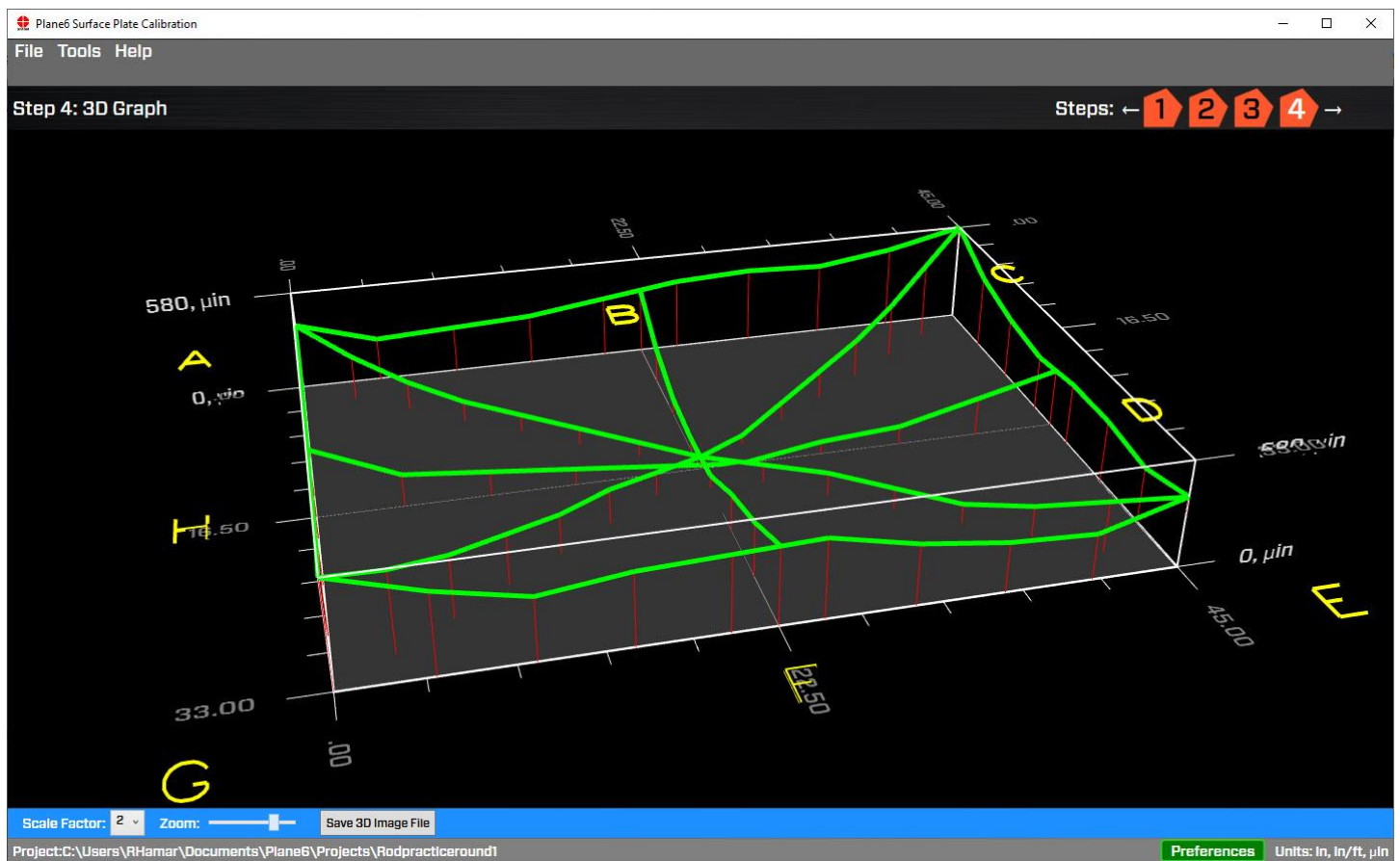
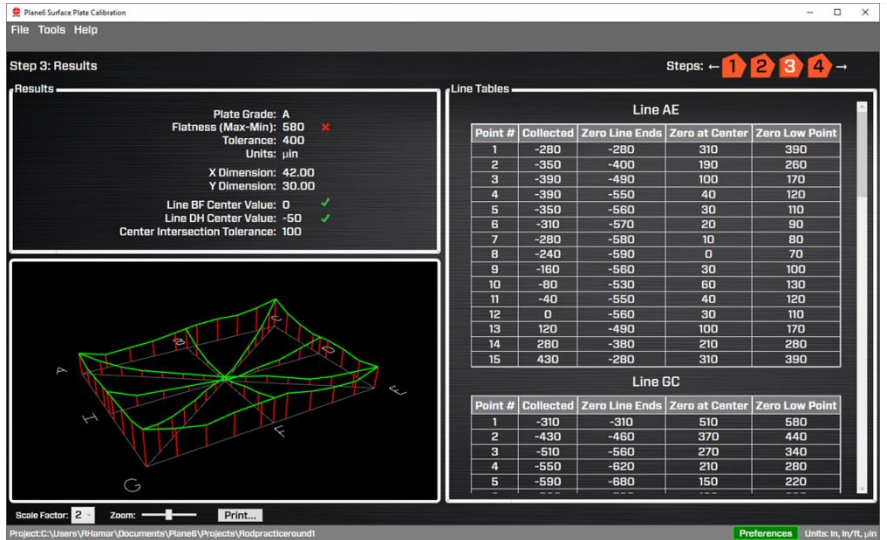

Figure 25 - Plane6 Step 4: Graph

Interpreting the Plus and Minus Signs in the Live Displays

The signs of the data displays indicate the position (high/low or left/right) of the target is relative to the laser beam. See the interpretation below.



Vertical Axis

A **+V center** value indicates the target is higher than the laser beam.

A **+V angular** value indicates the back of the target is *higher* than the front of the target.

A **-V center** value indicates the target is lower than the laser beam.

A **-V angular** value indicates the back of the target is *lower* than the front of the target.

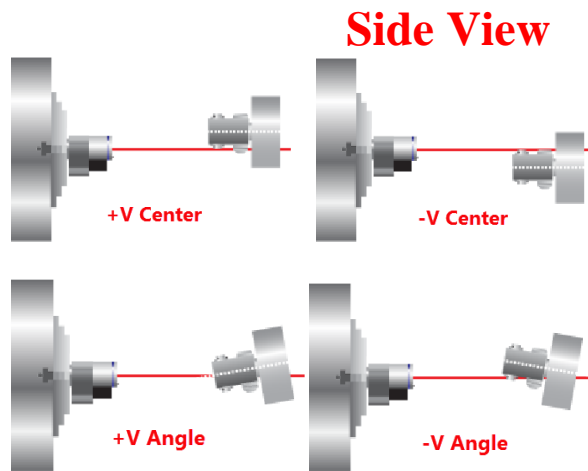

Horizontal Axis

A **+H center** value indicates the target is to the right of the laser beam when looking from the laser *into* the T-261 target.

A **+H angular** value indicates the back of the target is to the *right* of the front of the target when looking from the laser *into* the T-261 target.

A **-H center** value indicates the target is to the left of the laser beam when looking from the laser *into* the T-261 target.

A **-H angular** value means the back of the target is to the *left* of the front of the target when looking from the laser *into* the T-261 target.

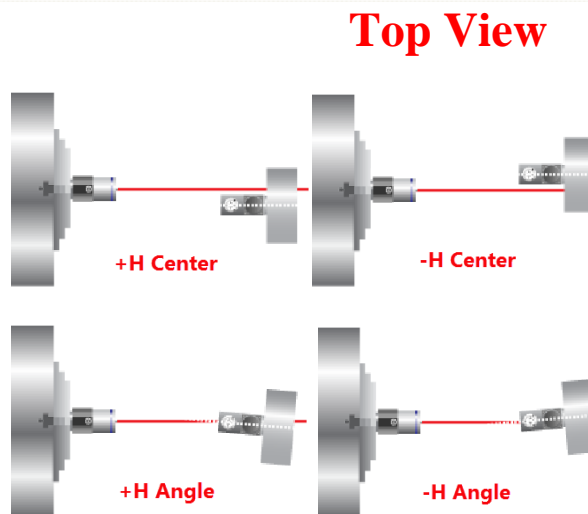

L-703SP - How It Works

Step-by-Step Surface Plate Calibration Procedure

NOTE – it is best to start off by assembling the L-703S and L-703SP-LM first (see Step 3) and turn on the laser to allow it to warm up. We recommend a 30-minute warm-up period.

Step 1 – Plate Setup

These parameters need to be entered:

- the plate border size (default is 1.5 in. 37 mm). See Step 2 to determine what border to use.
- the plate grade,
- the plate size in X & Y,
- the number of points to measure for the horizontal, vertical and diagonal line segments,
- pick the label location,
- the plate serial number,
- the temperature for the top and bottom of the plate and,
- the alignment tolerance.

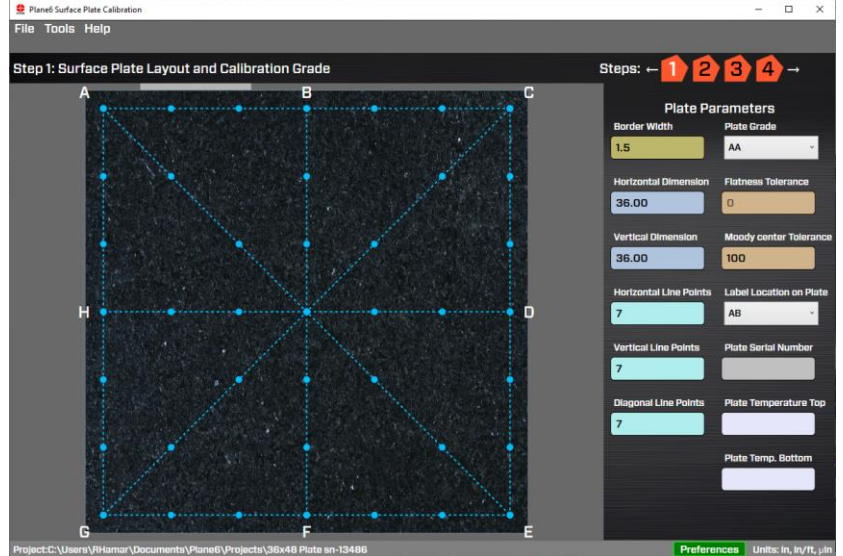

Step 2 – Set Corner and Mid-Point Locating Tools

A corner-locating tool is supplied to help align the straight edge to the line segment, speeding up the process.

Note – We supply a 2.0 in. corner tool, but we can make up different sizes if desired. Enter the value for the tool in Border Width in Plane6 Step 1.

- a. The tool self-aligns to the plate's corner and the suction cup holds it in place.
- b. Next, use a tape measure to mark the midpoint for each perimeter segment line.
- c. Place the midpoint location tool on the point for use when you get to this segment.

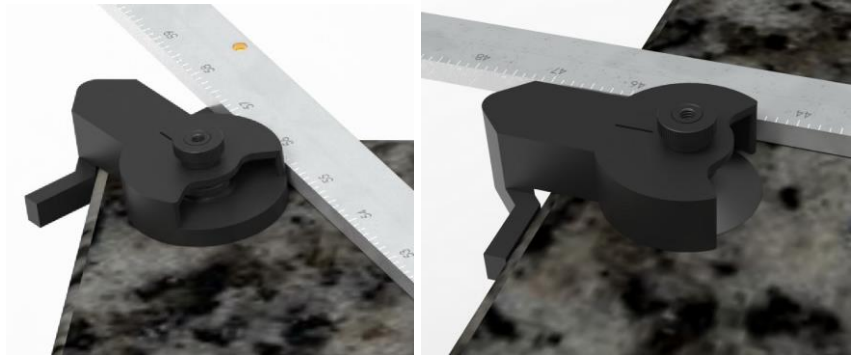

Step 2 – Place Straight Edge on the Diagonal Segment

Plane6 preselects the line sequence that you will measure. This can be overridden but this sequence was selected to minimize the time it takes to take all the data. To measure the diagonal:

- Locate the correct diagonal segment using the plate label location to orient yourself (see screen below).
- Place the side of the straight edge with the ruler so it is to the right of the corner locator when viewed from the Laser End. See image. In other words, you always want the *scale side* of the ruler to be touching the locator tool.
- Position the end of the straight edge to line up with the line on the rotating-edge-alignment tool.
- Now the straight edge is located next to the line segment that you need to measure such that when the target is put down against the straight edge, it is directly over the line segment.

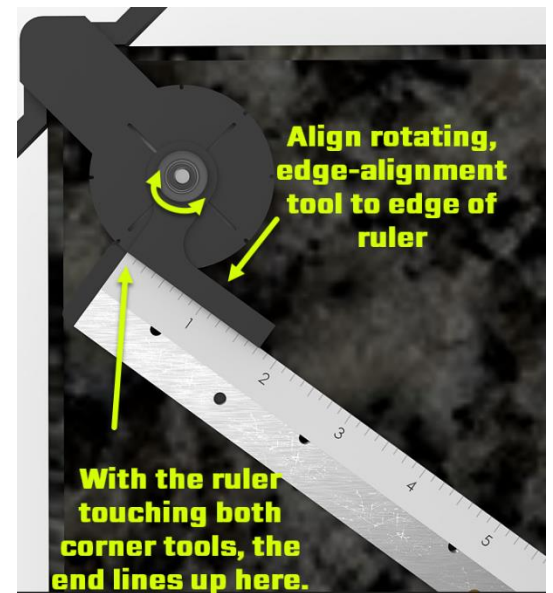
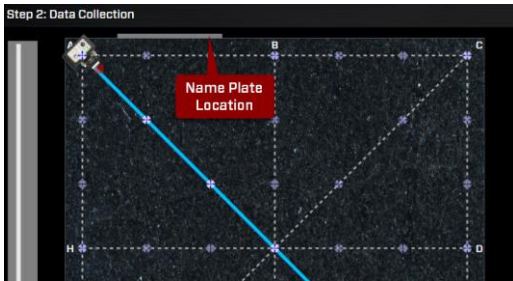

Step 3 – Assemble Laser and Laser Mount

Insert the L-703S Laser into the L-703SP-LM Laser Mounting Fixture and tighten the thumb screw very tight and make sure to keep the top of the laser level. Turn on the laser and make sure it is in *Double-Blink Mode* (See Page 2 of the manual). The LED will blink twice and pause when in *Double-Blink Mode*.

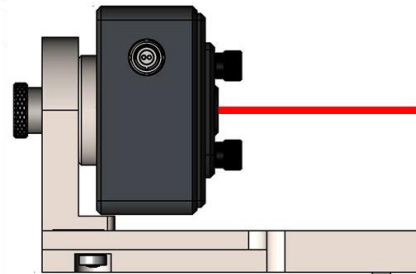

Step 3a –Place Laser Mount + L-703S on top of the straight edge

- a. Find the correct corner on which to place the A-703SP-LM from Plane6 Step 2 Measure Screen, keeping track of the name plate location. Normally this is on line AE.

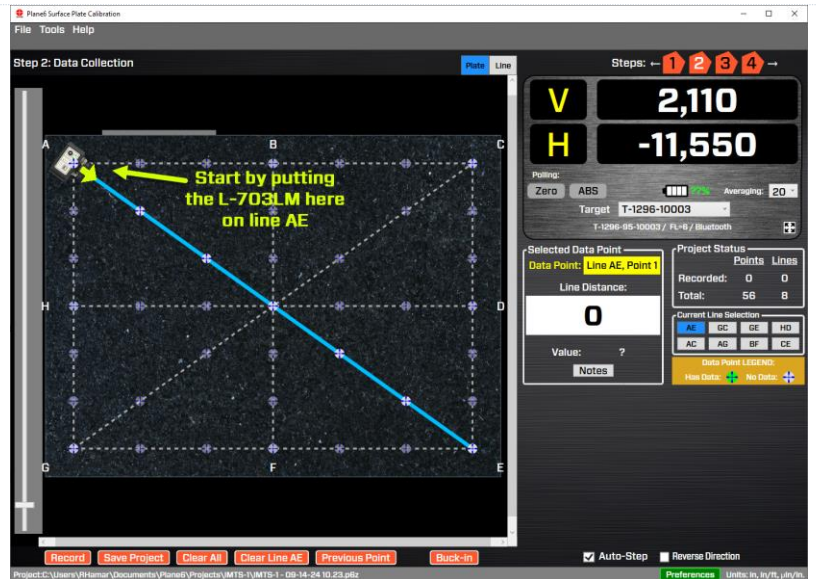
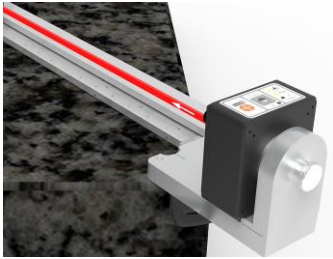

- b. Place the A-703SP-LM on top of the straight edge, aligning the channel (cutout) on the bottom to the straight edge. Then, holding down the straight edge, slide the laser fixture against the straight edge to make it parallel to the straight edge and line segment. You can squeeze them together so the bearings on the bottom of the laser fixture make contact with the straight edge.

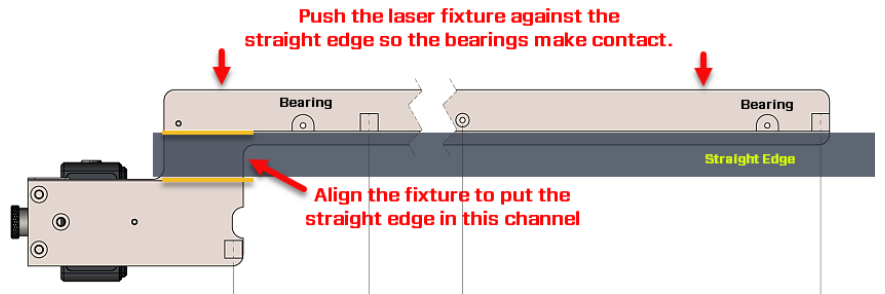

Note: When putting the A-703SP-LM on the straight edge make sure to line up the green mark on the fixture with the beginning of the ruler scale.

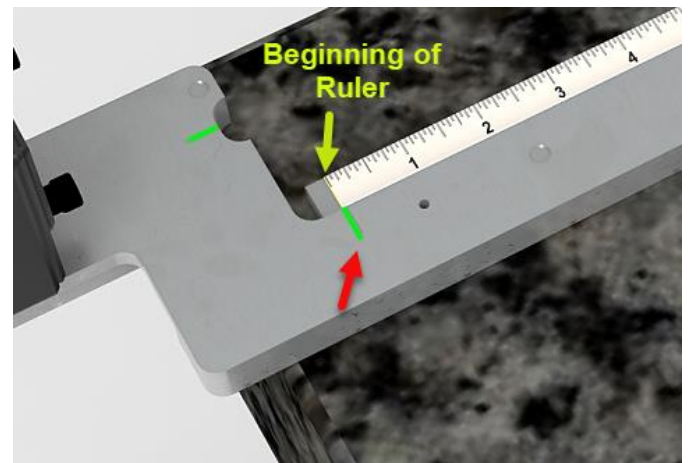

Step 4 – Assemble the T-1297 Target and A-1297-SP Measuring Base

Now assemble the T-1297 Target into the A-1297-SP Precision Measuring base. Notice that the T-1297 has an alignment ball. This will insert into the slot on the A-1297-SP to align the target to the A-1297-SP base's measuring feet. Tighten the thumb screw very tight.

Turn on the T-1297 and use *Center Mode*.

Note – do not use *Scanning Mode* as outlined on page 6. When you turn on the T-1297 it defaults to *Center Mode*. If you see the *On TGT LED* on top of the target blinking in red, then this means it has been set to *Scan Mode*. Press and hold the power button to turn it off and then turn it back on again to put it back into *Center Mode*.

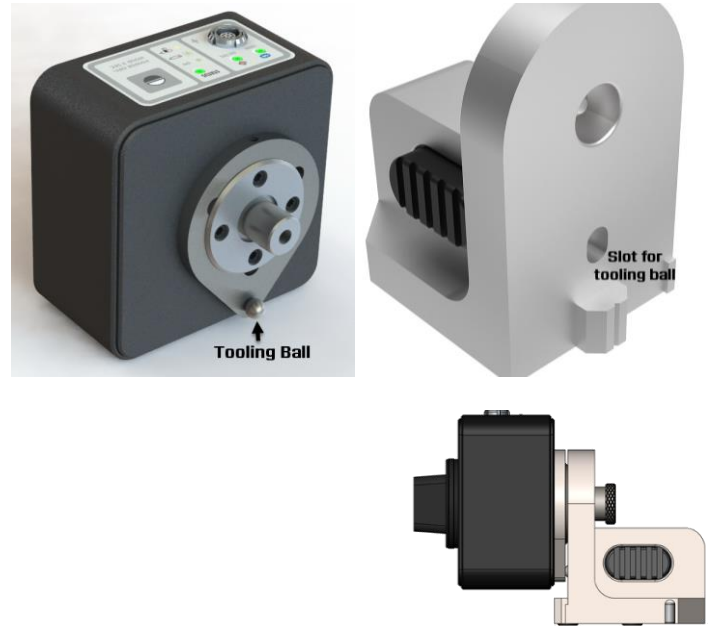

Step 4a – Place T-1297 Target and Base on the Plate

Place the T-1297 Target and Base on the plate near the laser, gently push it against the straight edge, and line up the *Measuring Plane* of the base with the zero point on the scale (see image). Check to make sure that the **H Axis** value is less than 30,000 μm . (760 μm), which it normally is.

Zero the display by clicking **Zero**.

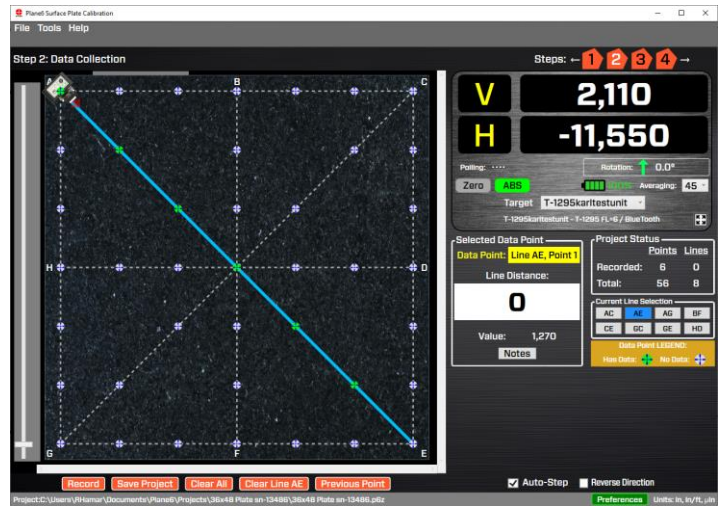

Step 4b – Move the T-1297 Target + Base to the Far End of Straight Edge

- a. Move the T-1297 Target + Base to the *far* end of the straight edge and gently push it against the straight edge.
- b. Adjust the H (yaw) and V (pitch) axis adjustments on the L-703S laser to tilt the beam until the values are less than:

H Axis: $\pm 5,000$
V Axis: $\pm 2,000$

This aligns the laser beam to the straight edge and puts it on the most accurate part of the PSD sensor.

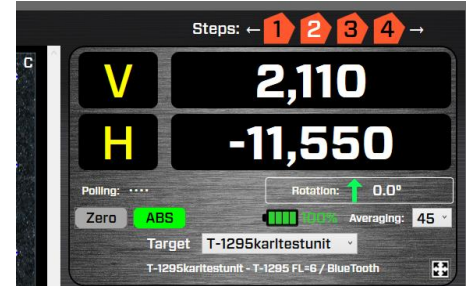
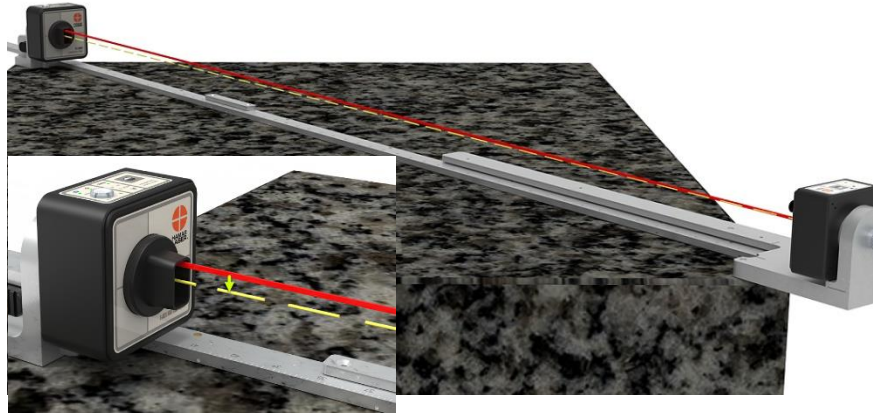

Step 4c – Move the T-1297 back to Near Position and Start Recording

Move the T-1297 Target back to the near point and click **ABS** button at the bottom of the screen. Then click **Record**. When positioning the target, line up the *Measuring Plane* (front edge of target base mounting surface) with the ruler dimension before hitting **Record**. In this case it should be on the zero (0) point on the ruler.

Note – for the zero point, there is a stop on the ruler to let you know you're at the right point.

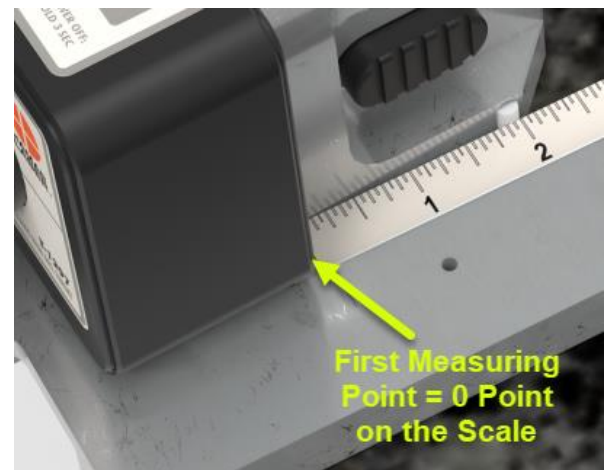

Step 5 – Move to Next Point and Continue Recording

Move to the next point by looking at the *Line Distance* display in **Plane6 Step 2** to tell you where to position the target. Click **Record**. Continue recording until all the points are taken.

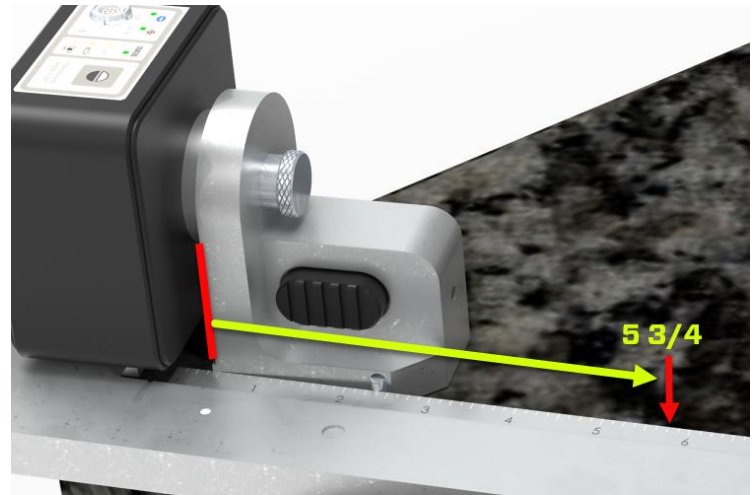
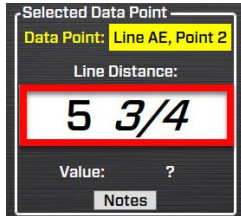
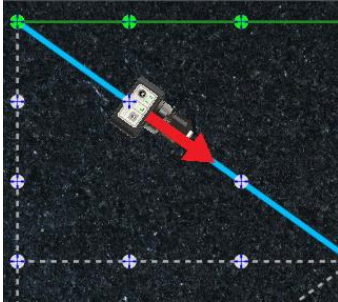

Step 5a – Note: Moving the Target when Taking Data

Note - when moving the target to the next point, it is important to only hold the straight edge to prevent it from moving. There are rubber feet on the bottom to help it from sliding, so light pressure on the straight edge will keep it from moving.

However, **DO NOT TOUCH THE L-703SP-LM** laser fixture since it does not have rubber feet and can be moved easily. Moving the fixture can cause the laser beam to move, causing measurement errors.

If the A-703SP-LM moves, we strongly recommend repositioning it, making sure it is properly touching the straight edge, clearing the data for the line segment, and re-recording the data for the line segment.

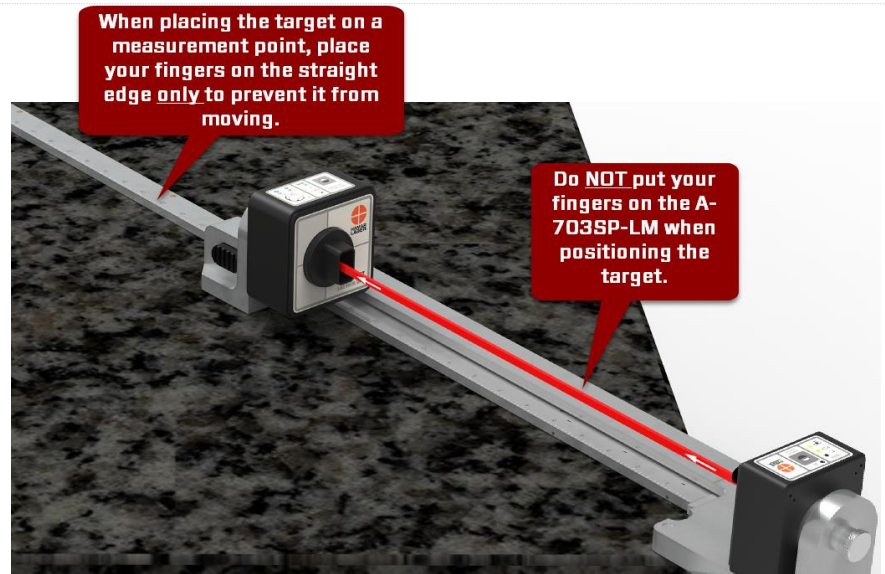

Step 6a - Note on Moving the Straight Edge

When moving the A-703SP-LM Laser Mount and A-703SP-SE Straight Edge to the next line, follow these basic steps:

- Place the straight edge on the line using the corner locating tool to position it correctly, as shown above in Step 2.
- Place the laser mount over the straight edge (see above) and slide it so it hits the straight edge at both ends. You can “pinch” them together to make contact but try to keep the straight edge from moving.
- Make sure to line up the start of the scale with the mark on laser fixture.
- Once the laser fixture is in place, do NOT touch it when you are taking data. This is because even small movements could cause the laser to move especially at the far end of the line, which would require restarting the data taking for the line segment.
- You can put your hand on the straight edge to help prevent it from sliding.

Note: if you change the straight edge to a different length, we recommend you redo the laser Buckin as noted in Step 4. A different straight edge will have a different straightness profile, so the laser will need to be adjusted to be parallel to the new straight edge.

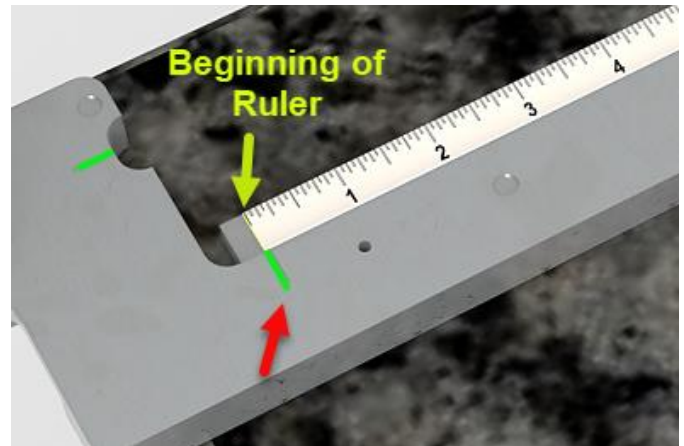
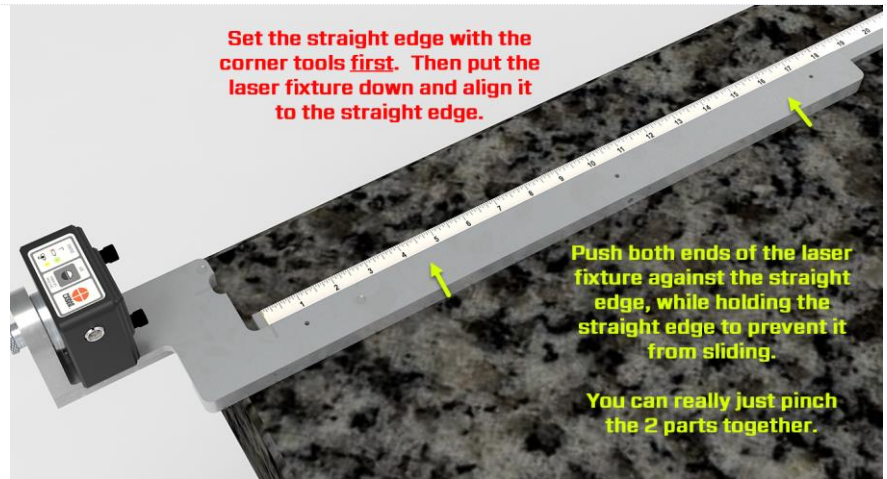

Step 6b – Move Laser to Second Diagonal and Record Data

- Plane6 automatically moves the recording line segment to next line as shown in the *Current Line Selection* table, which is GC.
- First take off the L-703SP-LM Laser Mount and set it aside.
- Then move the straight edge to the second diagonal using the corner locator tools to position the straight edge. *Note - the location of the target icon is where to put the laser fixture.* Again, make sure the straight edge is to the right of the corner locating tools and aligned with the mark as shown above.
- Place the L-703SP-LM Laser Mount on the straight edge as shown Step 3a above. Place the target at the near position and you are ready to record.

Project Status		
	Points	Lines
Recorded:	49	7
Total:	56	8

Current Line Selection			
AE	GC	GE	HD
AC	AG	BF	CE

Data Point LEGEND:
 Has Data: + No Data: +

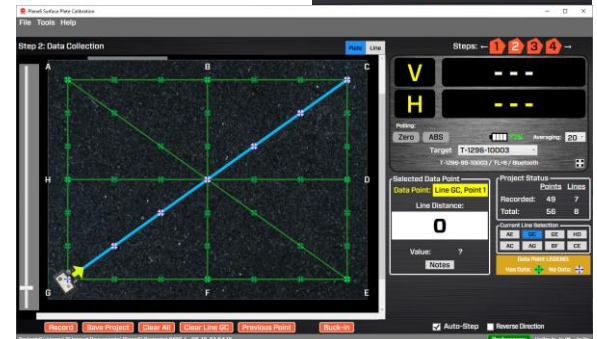

Note - you do not need to re-adjust the laser beam since you are using these straight edge, so it should hold its position and thus always be ready to take data.

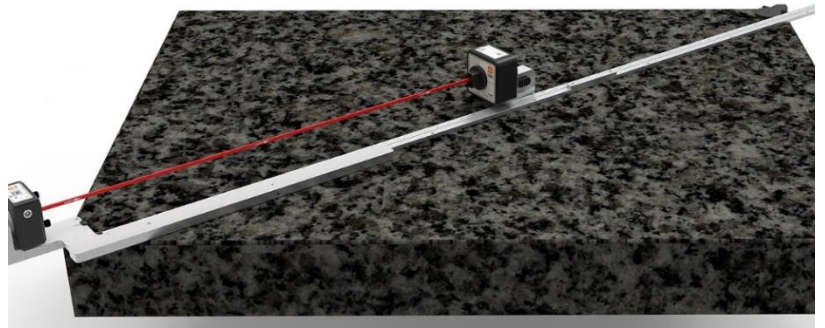

Step 7 – Move Laser and Straight Edge to Outside Edge and Record Data

Now we move to next line segment, an outside edge, as shown in the *Current Line Selection* table (see below), usually Line GE. Pay attention to which edge to record, always looking at the name plate locator to orient yourself. Find the straight edge that best matches the length of that side of the plate. See Step 2 for instructions on lining up the straight edge to the corner locating tool.

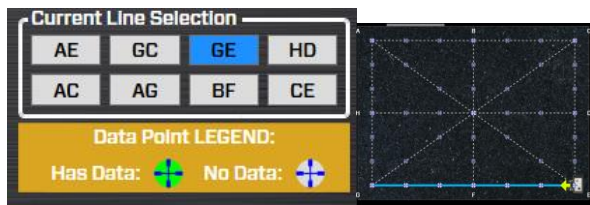

Note – we recommend that the extra length of the straight edge be no longer than 1/3 of the edge of the plate. This is to ensure that the straight edge does not move around when you are taking data. This can happen because as the straight edge gets longer relative to the plate edge, it tends to want to fall off the plate.

Again, when using the corner edge tool, always put the scale side touching the tool.

Place the L-703SP-LM Laser Mount on the straight edge as shown Step 3a above. Place the target at the near position and you are ready to record.

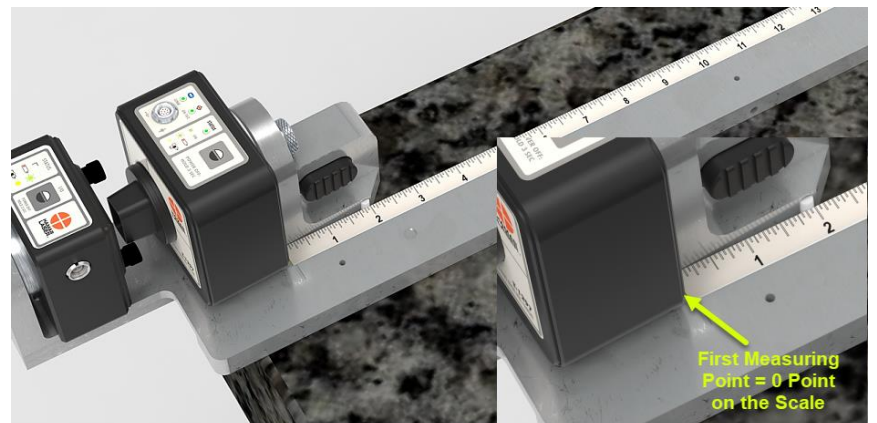
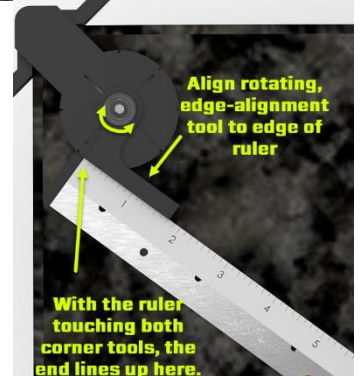
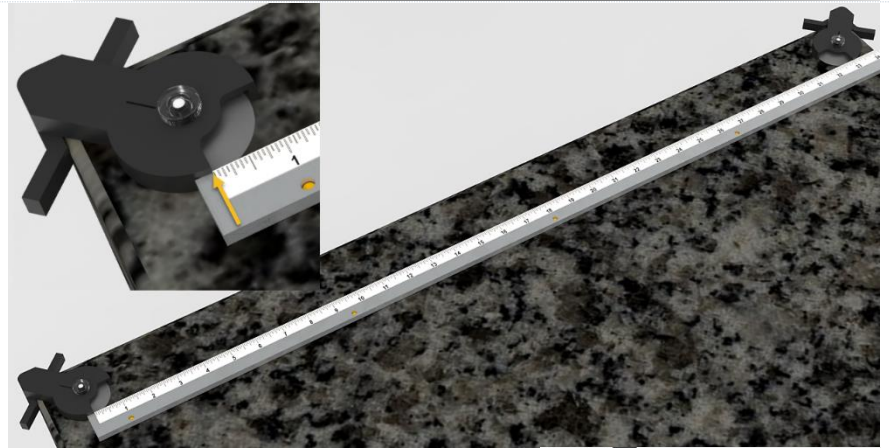

Step 7b - Record Second Outside Edge of Plate

Locate the second outside edge recommended by Plane6, usually Line HD and repeat the process in Step 7a



Step 7c – Record Mid-Point Line Segment

Using the mark made by the Mid-Point Marking Tool (see Step 1), position the Corner Locating Tool on the midpoint of the outside edges and align the mark on the locating tool with the mark on the plate.

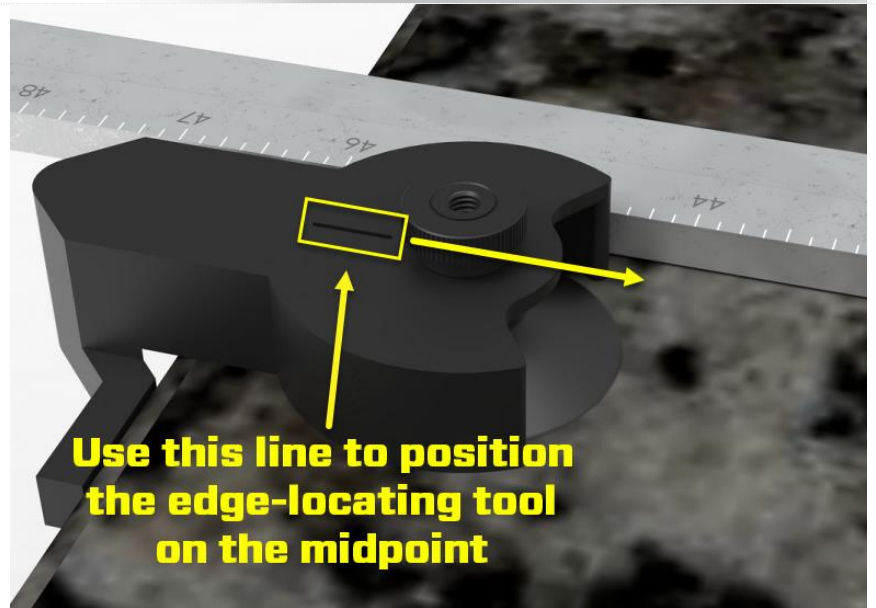

Position the straight edge to the right of the Corner Locating Tool (when looking from the Laser End of the straight edge toward far end).

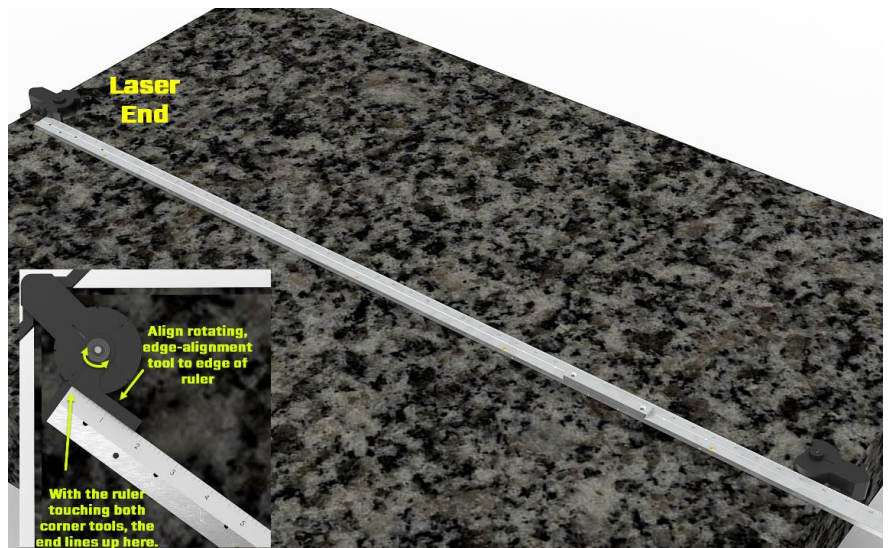

As before, place the A-703SP-LM fixture on the side recommended by Plane6 and place the target in the near position and hit Record. Continue taking data for the whole segment.

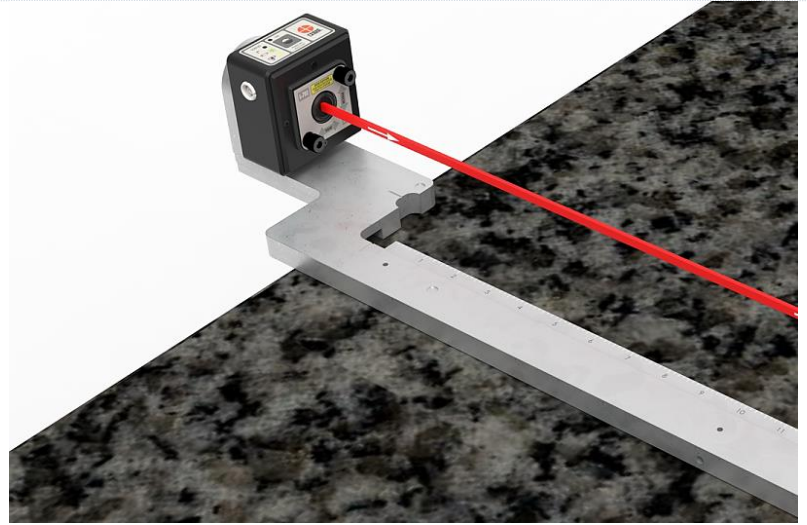

Step 8 - Record the Rest of the Line Segments

Record the rest of the line segments, following the recommended sequence from Plane6.

Project Status	
	Points Lines
Recorded:	96 8
Total:	96 8

Current Line Selection			
AC	AE	AG	BF
CE	GC	GE	HD

Data Point LEGEND:
 Has Data: No Data:

Notes on taking data:

1. **Display Value Tolerance** - Pay attention to the H axis value. If the value gets higher than 30,000 $\mu\text{in.}$ (760 μm), then the Plane6 data display will turn orange indicating that this is too far off center in the horizontal axis. This may mean the laser fixture moved. Check to make sure the laser fixture is still against the straight edge. If not, then move them together again.

Move the target to the end of the straight edge and see if the orange color disappears. If so, this means it's back in spec. Then hit **Clear Line XX** to restart the data taking for the line segment.

If it's still orange, you can simply adjust the H axis until it's less than 30,000. Then hit **Clear Line XX** and retake the data for that line.

2. **Checking Recorded Data Points** - You can always check data values for a given point by hovering over it and seeing the values or by clicking on it and seeing the values in the table.

Steps:

V: 9,430
 H: 29,590

Polling: Rotation: 0.9°
 Zero ABS 87% Averaging: 45
 Target T-1295test
 T-1295test - T-1295 FL-6 / BlueTooth

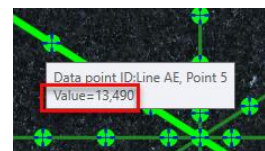

Selected Data Point

Data Point: Line AE, Point 5

Line Distance:
18 3/4

Value: 13,490

Notes

3. **Retaking a Data Point** - You can also click on a point and retake the data point if you think it is wrong.

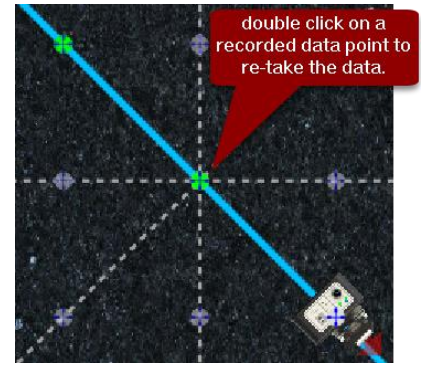

4. **Manually Picking Data Points** - You can turn off *Auto Step* if you want to move the target icon manually. First click on the line segment you want and then click on the point you want to record. The target icon should be over the point indicating it's ready to take data.



5. **Reversing Direction on a Line Segment** - You can also hit *Reverse Direction* to change the direction of a line if you need to.

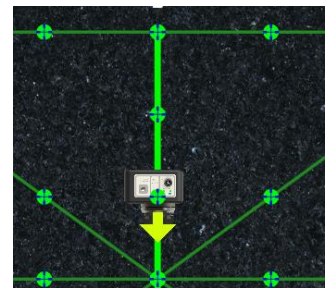

6. **Data Time-Outs**

There are two issues that can cause the data recording to restart:

a. The data buffer does not get enough samples for the averaging in the time allotted, so it will "timeout" (T/O). For example, if the Avg is set to 40 and the buffer only has 25 samples and the time has exceeded 4 seconds, you will see the timeout message. The formula for the T/O $T/O = (Avg/2)/13$ subject to a minimum of 3 seconds. So, for 40 avg, the T/O is $40/2 = 20/13 = 1.5$ but that is less than the minimum so the T/O is 3 secs.

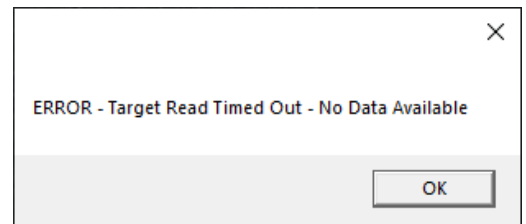

b. The software receives an "Off TGT" message from the target. This will trigger the software to "flush the buffer" and restart the data taking routine. This is to avoid potential bad data being recorded as the laser beam is being partially blocked. Plane6 will automatically retake the data unless **Cancel** is clicked.

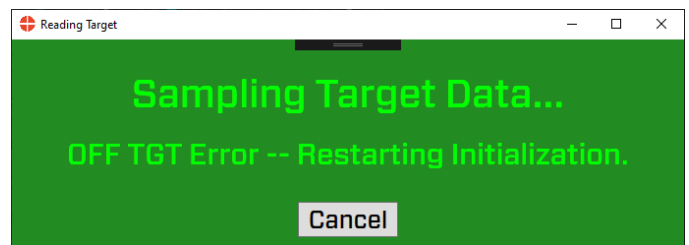

Step 9 – Review Results in Step 3 Results

Now click on Step 3 to view the results. The plate grade is shown, the tolerance for that grade and the overall flatness results from the data. A green check mark or red X tells whether it's in or out of tolerance.

There is also an additional check for the center point elevation difference as is directed in the B89 Standard. The tolerance is also displayed. According to the standard, if the center check is out of tolerance, it is recommended that the data be re-recorded. You may be able to retake one of the 2 center line segments to get it in tolerance. See page 35 **Centerline Tolerance Check** for a procedure to retake a line data.

Plane 6 also displays the data tables for each line segment. This is all displayed in the report.

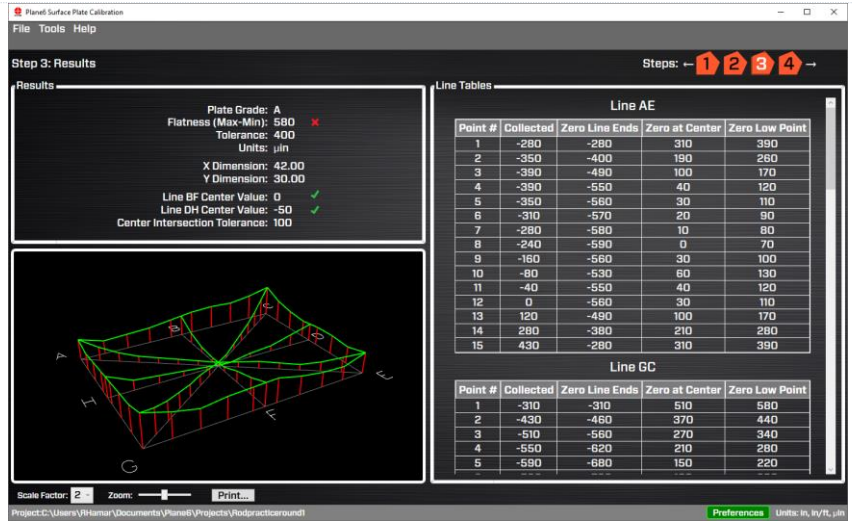

Step 10 – Review Graphical Results in Step 4 3D Graph

You can go to Step 4 3D Graph to look at an adjustable 3d graph of the results. You can zoom in/out and rotate the view to see the results. You can also magnify the elevation change to better show the results.

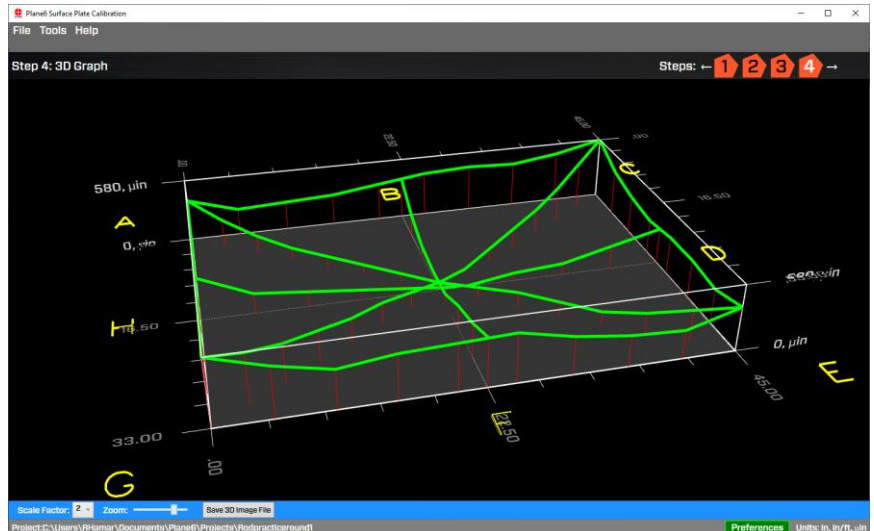

L-703SP - How It Works

Performing a Flatness Quick-Check on a Line-Segment after Lapping

One of the annoying parts of using electronic levels when re-surfacing a surface plate is you have to shoot the entire plate for flatness to see how the lapping process is going. This is a waste of time! With the L-703SP Surface Plate Calibration Systems, you can do quick-checks of a single line segment in about 5 minutes to see how much the flatness error has been reduced. Typically, you'll pick the line segment with the highest flatness error and focus on it as you lap the plate.

Here is the procedure to do a quick check of a line segment for flatness after you have finished the lapping and cleaned the plate.

Note - you don't really need to clean the entire plate but just the area that you will measure.

Step 1 - Set Up Laser Line & A-703SP-LM

Select the line segment you want to measure and select the matching length for the A-703SP-SE Straight Edge ruler. Use the corner/midpoint locating tool to set up the straight edge as shown above on pages 35, 41 or 42.

Then place the L-703SP-LM Laser Fixture on the straight edge as shown above.



Step 2 - Set Up Laser Line

Bring the T-1297 Target and A-1297-SP Target-Measuring Base to the first measuring point as you did above. Zero the display by clicking on the **Zero** button.

Due to the extremely high resolution, it's expected that the value won't be exactly zero due to some measurement noise, but they will be close.

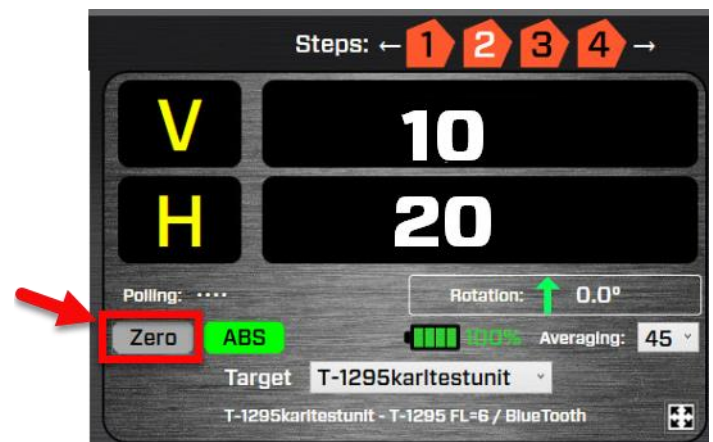
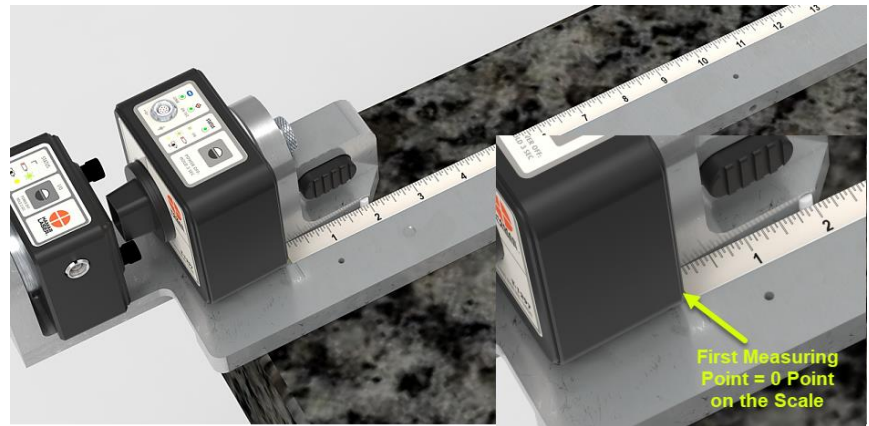

Step 3 - Move Target to Far Point and Adjust Laser's Pitch/Yaw

Move T-1297/A-1297-SP Base to the far end of the straight edge. Adjust the Pitch and Yaw knobs on the laser until you get as close to zero as you can go. Again, due to very high resolution and the limited angular adjustment resolution, it will be hard to get all the way to zero with the adjustments. This is ok because the sampling will remove most of the noise.

Go back to Point #1 and check to see if you have the nearly same values as when you zeroed it. If not, re-zero the target and repeat Step 3. You want to get the end values to be nearly the same. Maybe within 70-100 μin (1.5-2.5 μm).

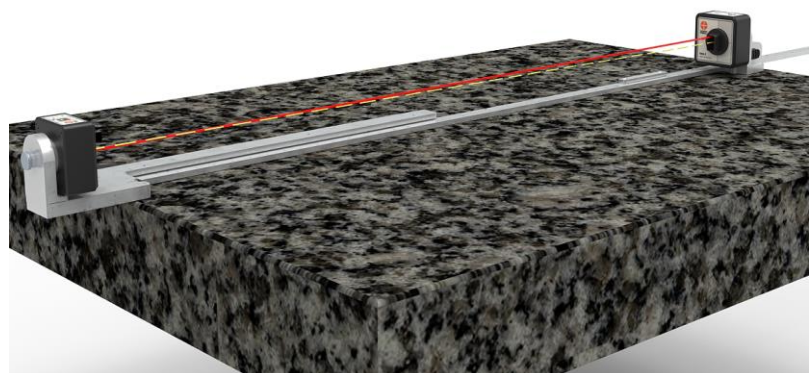

Step 4 – Setup Test Project

Set up a new project with the line length you want and the number of points you want to use to measure the line segment.

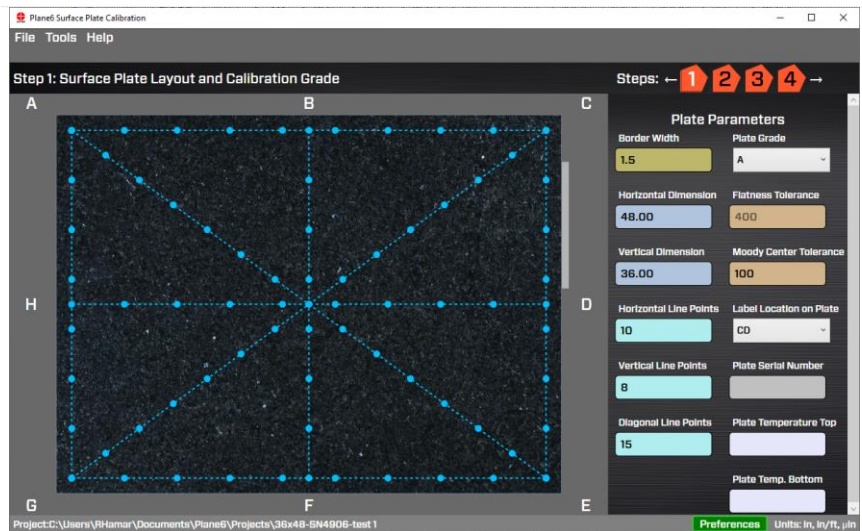

Step 4 – Record the Values

Go to Step 2 and select the line segment you want to record. Record the data for that line segment. You can then go to Step 3 and see the data in the table for that line segment. Note there won't be any calculations unless you have all the data recorded.

Note – you can easily export this data to a CSV file to open in Excel by clicking the Export Line menu item under the Tools menu.

You can then roughly estimate the flatness or do the math in an Excel file as shown below.

To roughly estimate the flatness, average the 2 end points and then subtract that value from each point. The highest (or most negative) value is the rough flatness error. Make sure to keep track of the signs!

Point #	Collected	Zero Line Ends	Zero at Center	Zero Low Point
1	-310	N/A	N/A	N/A
2	-430	N/A	N/A	N/A
3	-510	N/A	N/A	N/A
4	-550	N/A	N/A	N/A
5	-590	N/A	N/A	N/A
6	-590	N/A	N/A	N/A
7	-630	N/A	N/A	N/A
8	-670	N/A	N/A	N/A
9	-670	N/A	N/A	N/A
10	-590	N/A	N/A	N/A
11	-510	N/A	N/A	N/A
12	-430	N/A	N/A	N/A
13	-310	N/A	N/A	N/A
14	-160	N/A	N/A	N/A
15	0	N/A	N/A	N/A

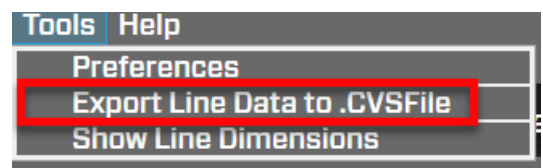

	1	2	3	4	5	6	7	8	9	10	11	12	13	14	15
Raw Values (μin)	-310	-430	-510	-550	-590	-590	-630	-670	-670	-590	-510	-430	-310	-160	0
Average of End Points	-155														
Raw values - Average		-275	-355	-395	-435	-435	-475	-515	-515	-435	-355	-275	-155	-5	
Max Corr. Val. = Flatness	-5														
Min Corr. Val. = Flatness	-515														

To get the true flatness, see the next page for the math calculations using Excel.

An example on how to do the Math to get the exact flatness values:

	1	2	3	4	5	6	7	8	9	10	11	12	13	14	15
Raw Values (µin)	-310	-430	-510	-550	-590	-590	-630	-670	-670	-590	-510	-430	-310	-160	0
Distance (in.)	0	4	8	12	16	20	24	28	32	36	40	44	48	52	56
Zero out end point	0	-120	-200	-240	-280	-280	-320	-360	-360	-280	-200	-120	0	150	310
Slope Calc*	5.54														
Slope Correction**	0	22	44	66	89	111	133	155	177	199	221	244	266	288	310
Corrected Flatness Value (µin)	0	-142	-244	-306	-369	-391	-453	-515	-537	-479	-421	-364	-266	-138	0
Max Corr. Val. = Flatness	0														
Min Corr. Val. = Flatness	-537														
* Slope Calc = (Far Point-Zero Point)/Total Distance															
** Slope Correction = Distance * Slope Calc															

Plane6 Sample Report



Plane6
Repeat_3 Results

Plate Grade: B
Flatness (Max-Min): 440 X
Tolerance: 200
Units: μ m

X Dimension: 39.13
Y Dimension: 27.13

Line BF Center Value: -10 ✓
Line DH Center Value: -10 ✓
Center Intersection Tolerance: 100

Plate Serial Number: 7490-89R
Technician Name:
Contact Info:
Recording Date:
Recording Time:
Temperature (Top): 72.4
Temperature (Bottom): 74.8
Project Notes:

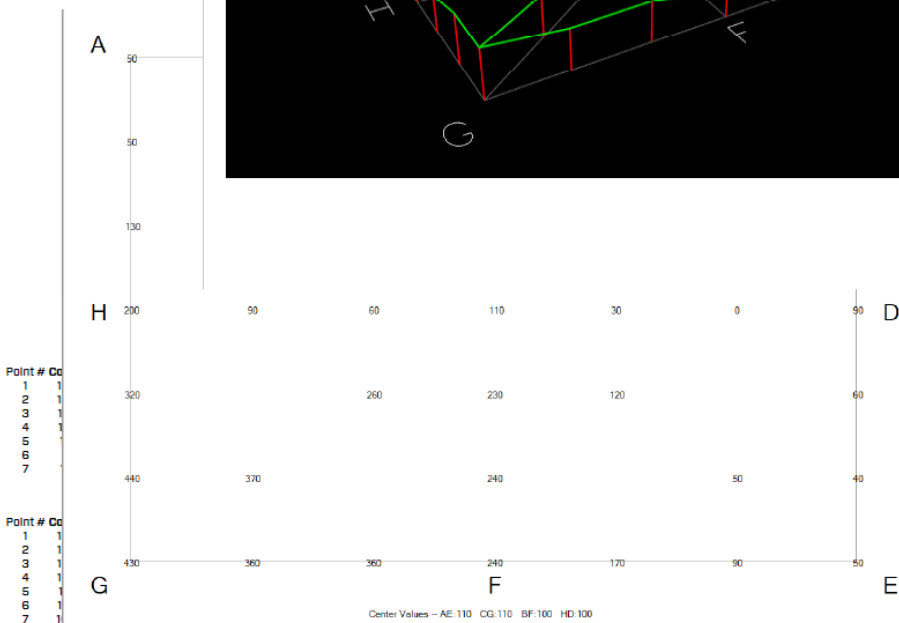
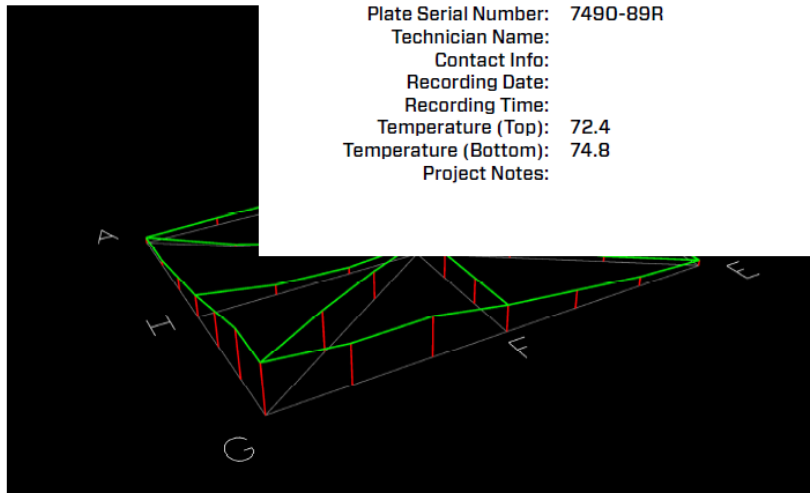

Point # Co
1 1
2 1
3 1
4 1
5 1
6 1
7 1

Point # Co
1 1
2 1
3 1
4 1
5 1
6 1
7 1

Point #	Collected	Ends to Outer Center	Zero Low Point
1	10,750	90	200
2	10,630	-20	90
3	10,590	-50	60
4	10,630	-10	100
5	10,550	-80	30
6	10,510	-110	0
7	10,590	-30	90

Point #	Zero Line Ends	Ends to Outer Center	Zero Low Point
1	10,710	50	160
2	10,630	-60	50
3	10,670	-50	60
4	10,750	-10	100
5	10,910	120	230
6	10,940	120	240
7	10,980	130	240

Appendix A – Installing Additional Microsoft Software

Installing Microsoft .NET Framework 4

You must have Microsoft .NET Framework installed before installing the Plane6 software. If you are unsure about whether you have Microsoft .NET Framework 4 installed on your computer, open the Control Panel. Window 7 users, select **Programs and Features**. Scroll down the list of installed software to locate Microsoft .NET Framework 4. If the program is not installed, follow the instructions below. Windows 10 & Windows 11, Microsoft .Net is preinstalled and user should not need to install. Follow steps below if .Net is missing from computer.

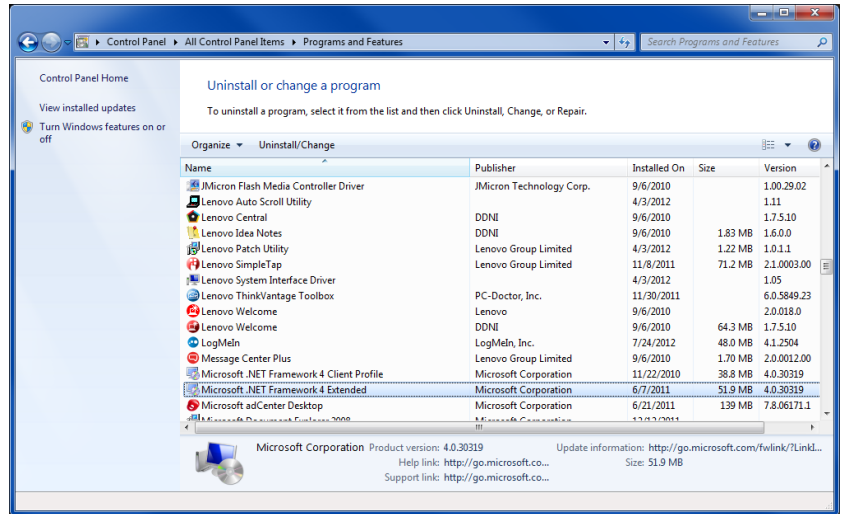

1. To install Microsoft .NET Framework 4, locate the folder **MS_Framework_4_X86_X64** on the Plane6 installation USB drive. Open the folder and double-click **DOTNETFX40_FULL_X86_X64** to begin the installation. Follow the on-screen prompts to complete.

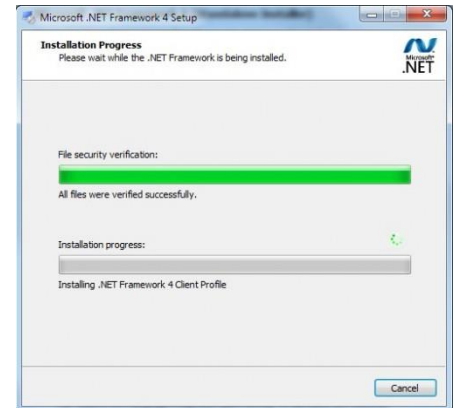

2. When the installation is complete, click **Finish** to close the installation program.

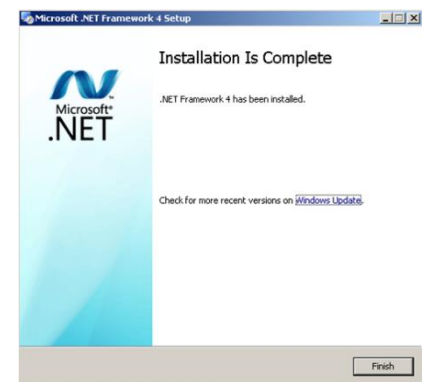

Appendix B – ANSI B89.3.7.2013 Standard Tolerance Table

Plane6 Software uses the tolerances for the standard plate sizes shown in Figure 29 below from the ANSI B89.3.7.2013 Standard for Granite Surface Plates.

For non-standard sizes, we use the formula from the standard:

“Flatness tolerance for surface plates, whose sizes are not listed in Table 1, is obtained from the following formula:

$$\text{Overall flatness tolerance } (\mu\text{m}) = 1 + 1.6 \cdot D^2$$

$$\text{Overall flatness tolerance } (\mu\text{in.}) = 40 + D^2/25$$

Where,

D = diagonal or diameter of the plate

The calculated flatness tolerance for grade AA is rounded up to the nearest 0.5- μm or 25- $\mu\text{in.}$ increment. The tolerance of grades A and B plates are 2 and 4 times, respectively, those for grade AA.”

Table 1 Common Sizes and Flatness Tolerances

Common Sizes Rectangular Surface Plates				Tolerance											
				Grade AA				Grade A				Grade B			
				Local Variation in Flatness (Using Repeat Reading Gage)		Overall Flatness		Local Variation in Flatness (Using Repeat Reading Gage)		Overall Flatness		Local Variation in Flatness (Using Repeat Reading Gage)		Overall Flatness	
U.S. Customary Size, in.	Metric Size, mm	U.S. Size, $\mu\text{in.}$	Metric Size, μm	U.S. Size, $\mu\text{in.}$	Metric Size, μm	U.S. Size, $\mu\text{in.}$	Metric Size, μm	U.S. Size, $\mu\text{in.}$	Metric Size, μm	U.S. Size, $\mu\text{in.}$	Metric Size, μm	U.S. Size, $\mu\text{in.}$	Metric Size, μm		
Width	Length	Width	Length												
12	12	300	300	35	0.9	50	1.3	60	1.5	100	2.5	110	2.8	200	5
12	18	300	450	35	0.9	50	1.3	60	1.5	100	2.5	110	2.8	200	5
18	18	450	450	35	0.9	50	1.3	60	1.5	100	2.5	110	2.8	200	5
18	24	450	600	35	0.9	80	2.0	60	1.5	160	4.0	110	2.8	320	8
24	24	600	600	45	1.2	80	2.0	70	1.8	160	4.0	120	3.0	320	8
24	36	600	900	45	1.2	100	2.5	70	1.8	200	5.0	120	3.0	400	10
24	48	600	1 200	45	1.2	150	4.0	70	1.8	300	8.0	120	3.0	600	16
30	48	750	1 200	45	1.2	180	4.5	70	1.8	360	9.0	120	3.0	720	18
36	36	900	900	45	1.2	150	4.0	70	1.8	300	8.0	120	3.0	600	16
36	48	900	1 200	45	1.2	200	5.0	70	1.8	400	10.0	120	3.0	800	20
36	60	900	1 500	60	1.5	250	6.5	80	2.0	500	13.0	160	4.0	1,000	26
36	72	900	1 800	60	1.5	300	7.5	80	2.0	600	15.0	160	4.0	1,200	30
48	48	1 200	1 200	60	1.5	200	5.0	80	2.0	400	10.0	160	4.0	800	20
48	60	1 200	1 500	60	1.5	300	7.5	80	2.0	600	15.0	160	4.0	1,200	30
48	72	1 200	1 800	60	1.5	350	9.0	80	2.0	700	18.0	160	4.0	1,400	36
48	96	1 200	2 400	75	1.9	500	13.0	100	2.5	1,000	26.0	200	5.0	2,000	52
48	120	1 200	3 000	90	2.3	700	18.0	120	3.0	1,400	36.0	240	6.0	2,800	72
60	120	1 500	3 000	90	2.3	750	19.0	120	3.0	1,500	38.0	240	6.0	3,000	76
72	96	1 800	2 400	90	2.3	600	15.0	120	3.0	1,200	30.0	240	6.0	2,400	60
72	144	1 800	3 600	100	2.5	1,100	28.0	140	3.5	2,200	56.0	280	7.0	4,400	112
Round Surface Plates Diameter				Round Surface Plates Local Variation in Flatness (Using Repeat Reading Gage)				Round Surface Plates Local Variation in Flatness (Using Repeat Reading Gage)				Round Surface Plates Local Variation in Flatness (Using Repeat Reading Gage)			
U.S. Customary Size, in.	Metric Size, mm	U.S. Size, $\mu\text{in.}$	Metric Size, μm	U.S. Size, $\mu\text{in.}$	Metric Size, μm	U.S. Size, $\mu\text{in.}$	Metric Size, μm	U.S. Size, $\mu\text{in.}$	Metric Size, μm	U.S. Size, $\mu\text{in.}$	Metric Size, μm	U.S. Size, $\mu\text{in.}$	Metric Size, μm		
12	300	35	0.9	50	1.3	60	1.5	100	2.5	110	2.8	200	5		
18	450	35	0.9	50	1.3	60	1.5	100	2.5	110	2.8	200	5		
24	600	35	0.9	80	2.0	60	1.5	160	4.0	110	2.8	320	8		
36	900	45	1.2	100	2.5	70	1.8	200	5.0	120	3.0	400	10		
48	1 200	45	1.2	120	3.0	70	1.8	240	6.0	120	3.0	500	12		

GENERAL NOTES:

- (a) Dimensions of length and width for common sizes are nominal dimensions only. The tolerances in this Table apply to sizes within $\pm 5\%$ of the nominal sizes listed. For guidance on recommended tolerances on sizes outside the listed common sizes, see para. 4.3.4.1. For flatness tolerances on surface plates not covered explicitly by this Standard, it is recommended that the manufacturer and buyer agree on the expected tolerance before a contract is concluded.
- (b) For granite reference flats smaller than the sizes listed above (commonly known as “toolmakers’ flats”), consult the manufacturer for tolerances supplied.

Figure 26 - ANSI B89.3.7.2013 Flatness Tolerance Table