

T-1295 5-Axis T-1296 5-Axis Multi-Purpose Targets

Multi-purpose targets for lathe
and machining center alignments

Target Features

Hamar Laser's T-1295/T-1296 5-Axis Targets are designed work with our L-702SP Spindle/Machine Tool Laser. With Bluetooth communication and multiple measuring axes, the T-1295/T-1296 targets are multi-purpose targets that can be used for many different applications.

- ✦ Applications include:
 - Flatness/straightness of surfaces.
 - Spindle alignments (center and angular) on ID/OD grinders, lathes, rotary-dial machines and turning centers..
 - Straightness/flatness of linear axes or guideways on boring mills, gantries, lathes, machining centers, multi-turn machines, VTLs.
- ✦ Offers 3 measurement modes:
 - *Center Mode* - 2-axis center measurement for use with the L-702SP's through-beam.
 - *Angular Mode* - 2-axis angular measurement for use with the L-702SP's through-beam.
 - *Flatness Mode* - single-axis flatness measurement for use with the L-702SP's auto-rotating laser plane.
- ✦ PSD (Position Sensing Detector) Size:
 - T-1295: 1.3 x .51 in. (33x13 mm) PSD
 - T-1296: .39 x .39 in. (10x10 mm PSD)
- ✦ Resolution:
 - *Center* (2 axis & 1 axis):
 - T-1295: .00002 in. (0.0005 mm)
 - T-1296: .00001 in. (0.00025 mm)
 - *Angular* (2 axis) – Standard 3 in. Lens:
 - T-1295: .00008 in./ft. (0.007 mm/m)
 - T-1296: .00004 in./ft. (0.0035 mm/m)
 - *Angular* (2 axis) – High-Res 6 in. Lens:
 - T-1295: .00004 in./ft. (0.0035 mm/m)
 - T-1296: .00002 in./ft. (0.0018 mm/m)
- ✦ Wireless communication via Bluetooth Class 1 radio with 100 ft. (30 m) of communication range.
- ✦ Accuracy is Center: <0.25% of change in measurement
Angle: <0.50% of change in measurement
- ✦ PSD concentric to the mounting stud to < .0003 in. (0.008 mm).
- ✦ The T-1295/T-1296 are designed so the measuring plane of the target is right at the face plate of mounting stud giving better accuracy on spindle alignments.
- ✦ Accelerometer rotation axis (6th axis) helps to orient the PSD sensor axes to the alignment axes of the spindle.
- ✦ Lithium polymer rechargeable battery with 14 hours battery life.



T-1295 Target with 3 in. (75 mm) with Lens Mounted in Spindle



T-1295 Target Mounted in T-242 Straightness &
T-243 Flatness Measuring Bases



Hamar Laser Instruments, Inc.
5 Ye Olde Road Danbury, CT 06810
Phone: 800.826.6185 Fax: 203.730.4611
Int'l: +1.203.730.4600
E-mail: sales@hamarlaser.com www.hamarlaser.com
[Click here](#) for a list of our distributors.



Specifications

T-1295 / T-1296 5-Axis Multi-Purpose Targets

Dimensions	3.23 x 3.23 x 1.8 in. (82 x 82 x 45 mm) – see more details below
Sensor	T-1295: 33 x 13 mm 2-Axis PSD T-1296: 10 x 10 mm 2-Axis PSD
PSD Resolution	T-1295 Center Mode: .00002 in. (0.0005 mm) – 2 axis (X/Y) T-1295 Scanning Mode: .00002 in. (0.0005 mm) – 1 axis T-1296 Center Mode: .00001 in. (0.00025 mm) – 2 axis (X/Y) T-1296 Scanning Mode: .00001 in. (0.00025 mm) – 1 axis
Angular Lens Resolution	T-1295-AO-3 3 in. (75 mm) focal length: .00008 in/ft (0.007 mm/m) T-1295-AO-6 6 in. (152 mm) focal length: .00004 in/ft (0.003 mm/m) T-1296-AO-3 3 in. (75 mm) focal length: .00004 in/ft (0.0035 mm/m) T-1296-AO-6 6 in. (152 mm) focal length: .00002 in/ft (0.0018 mm/m)
PSD Accuracy	Center: <0.25% of change in measurement Angular: <0.50% of change in measurement
PSD Concentricity to Stud Mount	<.0003 in. (0.008 mm) - remaining errors removed by MultiTurn10 NORMIN procedure.
Measuring Range	Center V Axis: T-1295: ±.55 in. (±14 mm) T-1296: ±.12 in. (±3 mm) Center H Axis: T-1295: ±.16 in. (±4 mm) T-1296: ±.12 in. (±3 mm) Angle 3 in. (75 mm) Lens - V Axis: T-1295: ± 11.4° (2.30 in/ft or 194 mm/m) T-1296: ± 2.5° (.51 in/ft or 43 mm/m) Angle 3 in. (75 mm) Lens - H Axis: T-1295: ± 3.8° (.78 in/ft or 65 mm/m) T-1296: ± 2.5° (.51 in/ft or 43 mm/m) Angle 6 in. (152 mm) Lens - V Axis: T-1295: ± 5.6° (1.14 in/ft or 95 mm/m) T-1296: ± 1.3° (.26 in/ft or 21 mm/m) Angle 6 in. (152 mm) Lens - H Axis: T-1295: ± 1.9° (.39 in/ft or 65 mm/m) T-1296: ± 1.3° (.26 in/ft or 21 mm/m)
Rotation Sensor Resolution	0.1 deg. Accuracy: ±1 deg. (6th axis)
Wireless Range	Bluetooth Class 1 with 100 ft. (30 m) communication range
Material	Plastic cover and aluminum frame
Mounting Stud	.4995 in. (12.687 mm) diameter. 440C stainless steel, RC54-58 hardness. Can be customized.
Weight	T-1295/T-1296 Target: 15 oz. (452 g) T-1295 Lens: 2 oz. (57 g)
Battery	Lithium polymer rechargeable with 14 hours battery life. Target can be used while plugged in.
A/C Charging & Backup Cable	USB cable charges the target with an A/C USB wall adapter and also can be used as a communications backup cable.
Ambient Light Protection	Blinking laser capability removes ambient light effect on accuracy. The light shield is for using target in Center Mode to reduce ambient light effects in bright light conditions.
Measurement Modes	2-Axis Center, 2-Axis Angular Modes: Supports L-702, L-702SP and L-703 beam lasers. 1-Axis Scanning Mode: Supports L-702SP, L-730/L-740 Series, and L-750 Scanning lasers for measuring flatness of axes, surfaces and guideways.
Accessories	T-242 X-Y Target Stand – for measuring flatness/straightness on machine axes. T-243: Scanning-Mode Target Base – for measuring flatness/straightness of surfaces & axes. T-1295-AO-3: Angular Measuring Lens – for measuring spindle-axis pitch & yaw angular alignment. T-1295-AO-6: Hi-Res Angular Measuring Lens – for measuring high-accuracy, spindle-axis pitch & yaw angular alignment.

Specifications

T-1295 5-Axis Target



T-243 Flatness Measuring Base

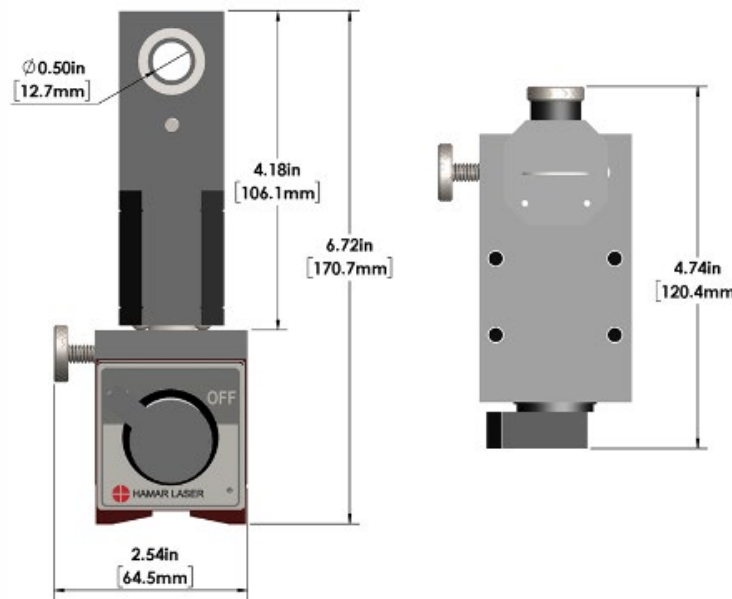

T-242 Straightness Measuring Base - 2-Axis Stage

