

L-702SP

5-Axis Machine Tool & Spindle Alignment System

Multi-purpose alignment tool with high accuracy and fast setups

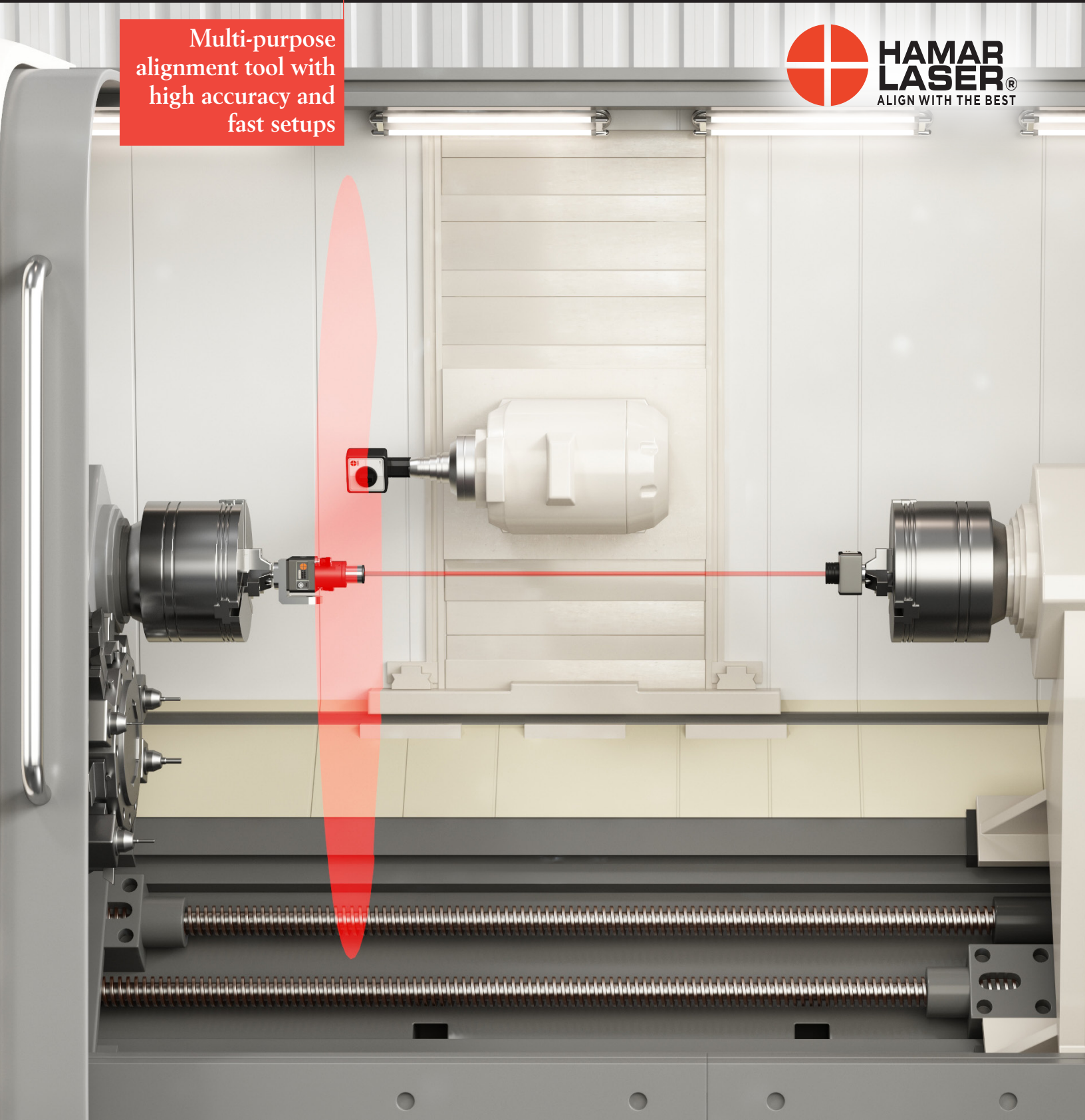

Machine Tool Axis and Spindle Alignment

The L-702SP 5-Axis Machine Tool and Spindle Alignment system is a powerful and versatile alignment system that is highly accurate, fast and easy to set up and can be used for many different machine tool applications. Its unique design makes it especially useful on difficult-to-align multiturn machines and 5-axis horizontal boring mills.

Typical applications include:

- Cylindrical OD/ID Grinders
- Horizontal Boring Mills, 3 & 5 Axis
- Lathes, CNC & Manual
- Machining Centers, 3 & 5 Axis
- MultiTurn Machines
- Rotary-Dial Machines
- Turning Centers
- Vertical Turning Lathes

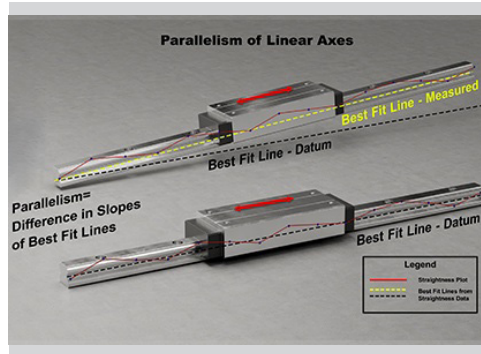
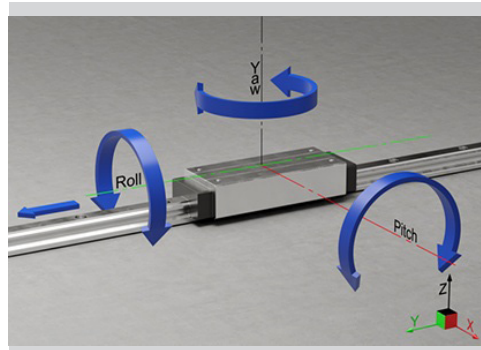
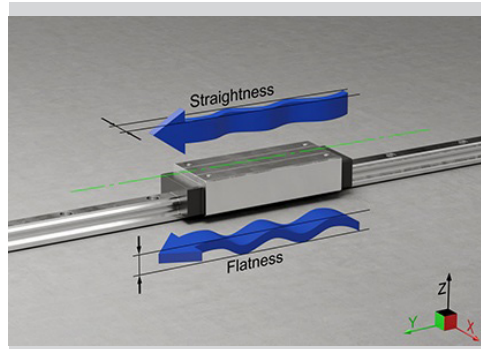
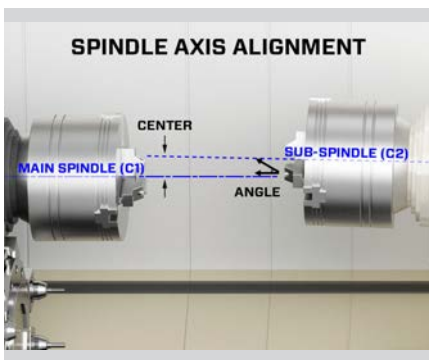

Alignment Capabilities

- Flatness & straightness of machine axes
- Flatness & straightness of guideways & surfaces
- Pitch angular axis check
- Roll angular axis check
- Spindle axis parallelism to tailstock/saddle guideways
- Spindle axis alignment to tailstock/subspindle in 4 axes
- Spindle parallelism/squareness of multi-turn milling axes
- Squareness of lathe cross-slide
- Squareness of machining axes
- Trammng spindles
- Yaw angular axis check

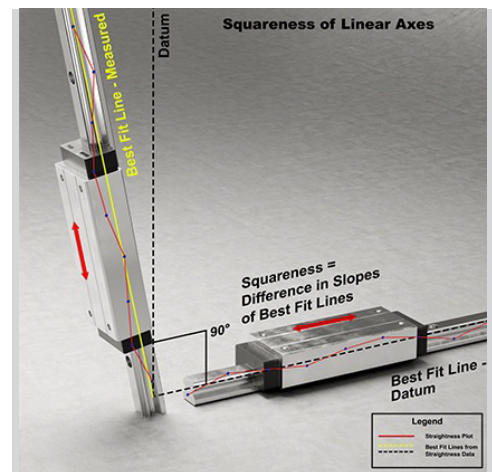

L-702SP Features

- Mounts in the spindle to project its rotation axis out to subspindle/tailstock
- Perpendicular auto-rotating laser scan plane measures straightness/squareness of other axes
- 100-foot (30 m) operating range
- Mag base mount for quick setup on tables, guideways or surfaces
- Right angle laser and target fixtures for fast and easy setups
- T-1295 5-Axis Target with large measuring range and Bluetooth communication
- Center resolution: .00002 in. (0.0005 mm)
- Angular resolution: up to .00004 in/ft (0.003 mm/m)
- Optional T-1296 Target has twice the resolution & accuracy
- Real-time measurement data
- Use lens accessory to measure pitch and yaw angular axis errors
- Multi-Turn10 Software records straightness/flatness/parallelism/squareness values
- Corrects mounting errors, calculates shim values and provides an alignment report with straightness graphs for each axis
- Vertical and horizontal angular adjustments to precisely align the laser to spindle's rotation axis.
- Lithium-ion rechargeable battery with up to 8 hours continuous runtime

L-702SP 5-Axis Machine Tool & Spindle Alignment System



L-702SP Laser

A Class II diode laser with vertical and horizontal angular adjustments to align it to the spindle's axis of rotation. Also has a laser scan plane that is perpendicular to the laser beam. The operating range is up to 100 feet (30 m).



T-1295 5-Axis Target

A 5-Axis wireless target with 2 accuracy options for measuring angle: Standard and High Resolution. Data is transmitted via Bluetooth to MultiTurn10 software. The 5 axes include:

- Horizontal & vertical center
- Horizontal & vertical angular
- Scanning for flatness/straightness



L-702MB Laser Mounting Base

Used to mount the L-702SP on flat surfaces for:

- Flatness measurements of surfaces
- Flatness, straightness & squareness measurements of machine tool axes
- Can also be used to hold T-1295 on spindle housings



L-702RA Right-angle Spindle Mount

Used to mount the L-702SP Laser and T-1295 Target at right angles to the spindle axis for use on:

- Boring mills
- Horizontal and Vertical Machining Centers
- MultiTurn machines to measure X & Y axes



T-242 Target Straightness Measuring Base

Used to hold the T-1295 5-Axis Target to measure straightness, pitch and yaw of machine tool axes and surfaces. Comes with X-Y micrometers to center the target to the laser beam in X (H) & Y (V) and mag base and set of posts.



T-243 Target Flatness Measuring Base

Used to hold the T-1295 5-Axis Target in Scanning Mode to measure flatness of machine tool axes and surfaces. The target rotates 360° on a very flat surface built into the T-243 fixture to ensure a flatness of $\pm .0001$ in. (0.0025 mm).

Benefits

Up to 50% Faster Alignments, Reduces Downtime

The L-702SP significantly speeds machine alignment by providing real-time alignment data, so without changing the setup, spindle and axis alignment errors can be quickly fixed, while watching MultiTurn10 software's display update with each adjustment. In most cases, alignment times can be reduced by 50%.

High Accuracy Reduces Scrap Rates

The L-702SP ultra-high resolution combined with software to correct mounting errors produces a very accurate alignment, less than .0001 in. (0.0025 mm), which can dramatically improve machine performance and reduce scrap rates.

Alignment Data in 10 Minutes

Insert the L-702SP into the spindle or the L-702MB Magnetic Base fixture and after a quick 10-minute setup, you're getting data.

Built-in 6-Step Alignment Software Procedure

An easy-to-follow, 6-step alignment procedure is built right into MultiTurn10, along with pop-up instructions, that makes a complicated alignment much simpler and easier to learn.

Complicated MultiTurn Alignment Checks Done in 2 Setups

The L-702SP mounts in the main spindle and after a quick setup, you can measure headstock spindle-axis parallelism with the guideways and alignment to the subspindle. Turn on its perpendicular laser scan plane and you can start measuring the linear axis of the 3-axis machining head for alignment to the main spindle. Use the L-702RA Right Angle Spindle Fixture for a quick second setup to get the rest of the axes.

How It Works: Lathes and MultiTurn Machines

One of the most important calibration factors for lathes and multiturn machines is the alignment of spindle axis of rotation (AOR) to the tailstock guideways or the saddle guideways. The other critical calibration factor is the alignment of the spindle's AOR to the tailstock, sub-spindle, turret or tool holder.

To check the alignment, the L-702SP is inserted right into the spindle chuck and aligned to the spindle's AOR, using the T-1295 5-Axis Target mounted in the tailstock or T-242 Target Stand. Once aligned, the L-702SP laser projects the spindle's AOR out to 100 feet (30 m) and becomes the reference from which the guideways, subspindle, machining head axes and toolholder can be measured and aligned. Even the largest multiturn machines can be quickly and easily aligned without changing setups, replacing heavy, cumbersome alignment test bars.



MultiTurn Alignment Procedure with L-702SP and MultiTurn10 Software



Step 1 - Machine Setup

Enter project name, chose axes to measure, and enter number of points, dimensions and tolerances. Insert L-702SP into the main spindle and the T-1295 into the subspindle/tailstock.



Step 2 - Qualify Laser

Rotate the spindle/L-702SP to the inverted position (6:00) and record a data point. Rotate spindle back 180 degrees to 12:00 and hit Record again. Display offsets are created so you can adjust the V & H angles to zero, aligning the laser to the spindle's rotation axis.



Step 3 - Record Axis Straightness

Insert T-1295 in the machining head, the subspindle/tailstock or toolholder and record the straightness data. For a multiturn machine, all 4 linear axes can be measured for straightness and squareness/parallelism in just 2 setups!



Step 3 - Alignment Results

Displays the vertical and horizontal straightness of each linear axis and the squareness/parallelism to the main spindle rotation or machining axes. The spindle's rotation axis parallelism to the main and/or saddle bed ways are also displayed.



Step 3 - Live Move Screen

To align the main spindle to the guideways, MultiTurn10 calculates the shim values and displays a live move screen, which shows graphics to illustrate the spindle's angular alignment to the guideways. The angular values & graphics update in real time as the shims are being added.



Step 4 - Results Summary and Axis Straightness Graph

Displays a summary of the alignment results and a graph of the straightness of each axis. If in tolerance, then proceed to Step 5 to check Headstock/Tailstock alignment.



Step 5 - Tailstock/Subspindle Record Screen

Record 6 data points by rotating the spindle/laser and target in the tailstock/subspindle and MultiTurn10 will calculate the rotation-axis alignment results in 4 axes.



Step 6 - Tailstock/Subspindle Live Move Screen

A live display for each of the 4 alignment values of the tailstock or subspindle relative to the headstock main spindle's rotation axis with shim and spacer calculations to fix the alignment. The alignment values update as shims and spacers are inserted or removed.

Machine Tool Applications

Machining Center Geometry

With the L-702MB Mag Base Accessory, L-702RA Right-Angle Spindle Mount, and T-242 Straightness Measuring Base, the L-702SP can be used with the T-1295 5-Axis Target in Scan Mode to align horizontal and vertical machining centers, perform these geometry checks:

- Flatness & straightness of X, Y & Z axes
- Squareness between the axes
- Pitch & Yaw angular checks of linear axes
- Parallelism of rotary axes to main axes
- Spindle trammung

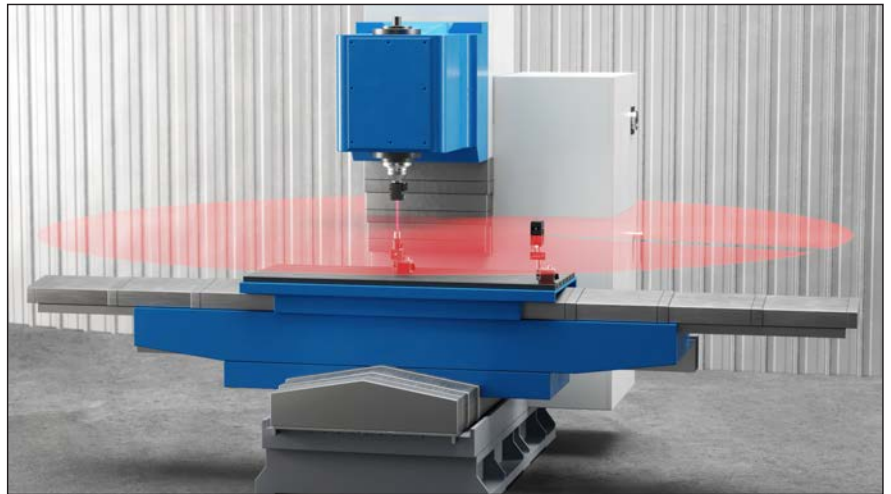

Lathes/Turning Centers

The L-702SP can also be used to align lathes and turning centers. Insert the L-702SP into the headstock spindle to check:

- Guideway flatness & straightness
- Pitch & Yaw angular checks of linear axes
- Spindle-axis parallelism to the tailstock guideways
- Spindle-axis parallelism to the saddle guideways
- Squareness of the cross slide.



Multi-Turn Machines

The L-702SP Spindle Laser with perpendicular scan plane gives the ability to check the machining axes on multi-turn machines. After setting up the L-702SP to the main spindle's C axis, it is switched to Scan Mode and the T-1295 is attached to the milling head and zeroed to measure the X axis for squareness and straightness in Z, the Y axis for squareness and straightness in Z and both the W & Z axis for flatness & straightness. With two setups, all these parameters can be measured:

- C1 to C2 spindle-axis alignment in 4 axes
- X, Y & Z axis flatness & straightness
- X-axis squareness to C1, Y & Z
- Y-axis squareness to C1, C2 & Z
- Z-axis parallelism to C1 & W
- Pitch and Yaw angular measurements for all axes

Compressor-Refurb Shop Cranks Out Rebuilds

“ Using Hamar's L-702SP system, each compressor housing is now individually aligned to the spindle of our horizontal boring mill in a simple 3-step process...The [T-1295] target, along with Hamar's system software, is used to square the part with the machine and adjust the spindle to the part centerline within tenths... We shaved a significant amount of time out of our alignment process with Hamar's system and gained the confidence that we are able to consistently hold the required tolerances. Most important, however, is the confidence and increased business from our customer! ”

Don W.

Hi-Tech Compressor & Pump Products, Inc.

L-702SP 5-Axis Machine Tool & Spindle Alignment System

Specifications

L-702SP Spindle Alignment Laser with Scan Plane

Mounting Stud	.4995 in. (12.687 mm) diameter - replaceable.
Weight	1.83 lbs. (0.83 kg)
Dimensions	5.85 x 3.09 x 2.60 in. (148.6 x 78.5 x 66.0 mm)
Material	Case: Anodized aluminum and 440C stainless steel Mounting Stud: 440C stainless steel, RC54-58 hardness
Laser Power	CLASS II, < 0.9 mw
Operating Range	Up to 100 feet (30 m)
Angular Adjustment	Coarse: .00025 in./ft. (0.02 mm/m) in angle
Resolution	Fine: .000025 in./ft. (0.002 mm/m) in angle
Beam Adjustment Range	±2.0 degrees
Beam Diameter	.20 in (5 mm)
Laser Plane Flatness Error	180-360° Sweep: 0.5 arc secs (.00003 in/ft. or 0.0025 mm/m) 90° Sweep: 0.25 arc secs (.000015 in/ft. or 0.0013 mm/m)
Laser Plane Step Error	180-360° Sweep: ±.00015 in. (0.0038 mm) 90° Sweep: ±.00008 in. (0.0016 mm)
Laser Plane Squareness to Beam	1 arc second (.00006 in/ft. or 0.005 mm/m)
Power Supply	3.4V lithium ion rechargeable batteries (4) with up to 8 hours battery life continuous use.

T-1295 5-Axis Target

Dimensions	3.23 x 3.23 x 1.8 in. (82 x 82 x 45 mm) - see more details below
Sensor	33 x 13 mm 2-Axis PSD
PSD Resolution	Center Mode: .00002 in. (0.0005 mm) - 2 axis (X/Y) Scanning Mode: .00002 in. (0.0005 mm) - 1 axis
Angular Lens Resolution	T-1295-AO-3 3 in. (75 mm) FL: .00008 in/ft (0.007 mm/m) T-1295-AO-6 6 in. (152 mm) FL: .00004 in/ft (0.003 mm/m)
PSD Accuracy	Center: <0.25% of change in measurement Angular: <0.10% of change in measurement
PSD Concentricity to Stud Mount	<.0003 (0.008 mm) - remaining errors removed by MultiTurn10 NORMIN procedure.
Measuring Range	Center V Axis: ±.55 in. (±14 mm) Center H Axis: ±.10 in. (±3 mm) Angle 3 in. (75 mm) Lens - V Axis: ± 11.4° (2.3 in/ft or 193.7 mm/m) Angle 3 in. (75 mm) Lens - H Axis: ± 3.8° (.78 in/ft or 64.6 mm/m) Angle 6 in. (152 mm) Lens - V Axis: ± 5.6° (1.14 in/ft or 95.2 mm/m) Angle 6 in. (152 mm) Lens - H Axis: ± 1.9° (.39 in/ft or 64.6 mm/m)
Rotation Sensor Resolution	0.1 deg. Accuracy: ±1 deg.
Wireless Range	Bluetooth Class 1 with 100 ft. (30 m) communication range
Material	Plastic cover and aluminum frame
Mounting Stud	.4995 in. (12.687 mm) diameter. 440C stainless steel, RC54-58 hardness. Can be customized.
Weight	T-1295 Target: 15 oz. (452 g) T-1295 Lens: 2 oz. (57 g)
Battery	Lithium polymer rechargeable with 14 hours battery life. Target can be used while plugged in.
Ambient Light Protection	Blinking laser capability removes ambient light effect on accuracy. The light shield is for using target in Center Mode to reduce ambient light effects in bright light conditions.
Measurement Modes	2-Axis Center, 2-Axis Angular - supports L-702, L-702SP and L-703 beam lasers. 1-Axis Scanning - supports L-702SP, L-730/L-740 Series, and L-750 Scanning lasers for measuring flatness of axes, surfaces and guideways.

L-702SP Spindle Laser with Scan Plane

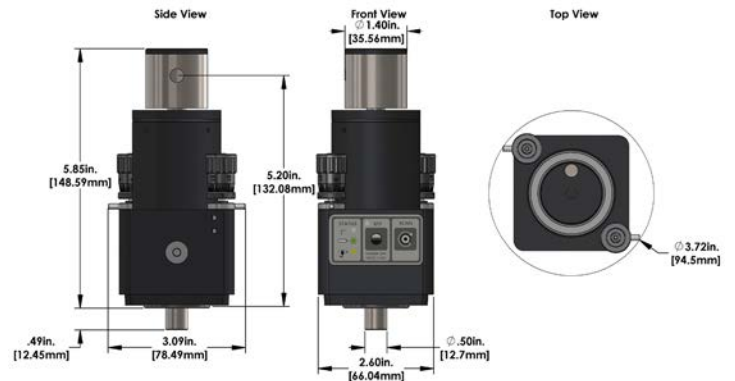

T-1295 5-Axis Target Dimensions



L-702RA Right-Angle Spindle-Mounting Fixture

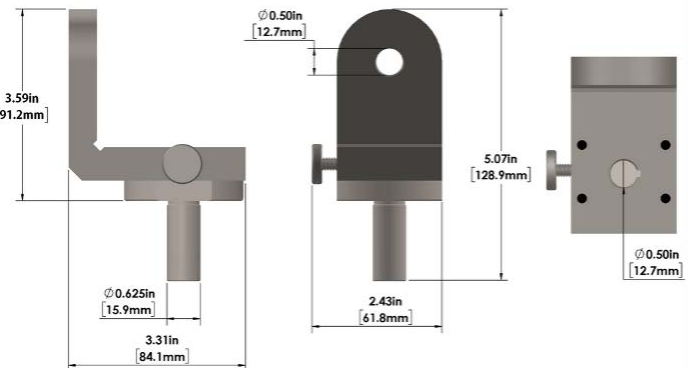

L-702SP Accessories

L-702RA Mounting Stud diameter	.625 in. (15.88 mm)
T-242 Adjustment Range	±.25 in. (± 6.35 mm) in X (H) & Y (V)
T-242 Adjustment Resolution	.0001 in. (0.003 mm)
T-242 Accessories	12.5 in. (317.5 mm) 3 pieces Magnetic base with 176 lbs (80 kg) holding power
T-243 Rotation Mount	Target-head rotates 360° to point at laser. Rotation flatness is ± .0001 in. (0.0025 mm). For use with all HLI L-730/L-740 Series scanning lasers
Material	440 stainless steel, aluminum and other materials, RC54-58 hardness for mounting stud
Weight	L-702MB: 3.86 lbs. (1.76 kg) L-702RA: 1.19 lbs. (0.54 kg) T-242: 5.13 lbs. (2.33 kg) with mag base and 3-piece post set T-243: 4.38 lbs. (1.99 kg) with mag base and 3-piece post set



Hamar Laser Instruments, Inc.
5 Ye Olde Road Danbury, CT 06810
Phone: 800.826.6185 Fax: 203.730.4611
Int'l: +1.203.730.4600
E-mail: sales@hamarlaser.com
www.hamarlaser.com