



Operations Manual

- A-1519 and A-1520 Series Type II Universal Wireless Targets
- A-910 Radio Transceiver/Hub
- Charging Station
- Configuration Utility
- Programmer's Reference

July 2024



**HAMAR
LASER**®
ALIGN WITH THE BEST

HAMAR LASER INSTRUMENTS, INC.
www.hamarlaser.com

Five Ye Olde Road, Danbury, CT 06810
Phone: (800) 826-6185 Fax: (203) 730-4611

WARRANTY

Hamar Laser Instruments, Inc., warrants each instrument and other articles of equipment manufactured by it to be free from defects in materials and workmanship under normal use and service, its obligation under this warranty being limited to making good at its factory any instrument and other article of equipment which shall, within one year after shipment of each instrument and other article of equipment to the original purchaser, be returned intact to Hamar with transportation prepaid, and which Hamar's examination shall disclose to Hamar's satisfaction to have been thus defective; other than this express warranty, Hamar neither assumes nor authorizes any other persons to assume for it any other liability or obligation in connection with the sale of its products.

This warranty is not applicable to instruments or other articles of equipment manufactured by other companies and limited by a warranty extending for less than one year. In such an event, the more limited warranty applies to said instrument or article of equipment.

This warranty shall not apply to any instrument or other article of equipment which shall have been repaired or altered outside the Hamar factory, or which has been subject to misuse, negligence, or use not in accord with instructions furnished by the manufacturer.

The software described in this manual is furnished under a license agreement and may be used or copied only in accordance with the terms of the agreement. It is against the law to copy the software on any medium for any purpose other than the purchaser's personal use.

The information in this manual is subject to change without notice. No part of this manual may be reproduced by any means, electronic or mechanical, without written permission from Hamar Laser Instruments, Inc.

**© Copyright Hamar Laser Instruments, Incorporated, 2024
5 Ye Olde Road, Danbury, Connecticut 06810**

Table of Contents

A-1519-2.4XBE/A-1520-2.4XBE Wireless Targets - Overview.....	1
Identifying Target Features.....	1
Managing the A-1519/A-1520 Battery Capacity.....	2
Resetting the Target.....	2
Connecting and Configuring the A-910 Radio Transceiver/R-1307 Readout.....	3
The Model R-1307 Readout.....	3
The A-910 Radio Transceiver/Hub.....	4
The A-910-2.4ZB/A-910-2.4XBE and Utility Software.....	5
Configuring the R-1307 for a Local Target.....	6
Setting the Target Network ID and System ID for the R-1307 Readout.....	7
Miscellaneous Display Messages.....	7
Wireless Communications Setup.....	8
Configuring the A-1519/1520 Target System Group.....	8
Setting the Target System ID and Target Network ID (A-1519/A-1520 Targets, A-910-900/2.4, A-910-2.4ZB/A-910-2.4XBE).....	9
Installing and Using the Wall-Mounted Charging Station.....	10
Software Installation and Configuration.....	12
Pre-installing the Common USB Port Driver (A-1519/1520 and A-910).....	12
Installing and Using the A-1519/1520 Type II Configuration Utility.....	13
Users Database.....	13
Initial Setup.....	13
Switching Between Normal Application Mode and Configuration Mode.....	17
Diagnostic Readout – Normal Application Mode.....	18
Diagnostic Readout – Debug Mode.....	19
Diagnostic Readout – Advanced Functions.....	20
Updating the Firmware.....	21
Appendix A – Equipment Specifications.....	26
Appendix B – Interpreting the A-1519/1520 Type II Calibration Reports.....	27
Appendix C – Agency Certifications.....	29
Appendix D – Dimensional Drawings.....	31
A-1519 Type II Universal Wireless Target.....	31
A-1519 RS-485 Cable Diagram.....	32
Appendix E – Using the A-151945 4-Port Target Communication Wired Hub.....	33
Appendix F – Programmer’s Reference.....	34
Appendix G – Troubleshooting Guide.....	40
Appendix H – Care and Cleaning of Target Optics.....	43
Appendix I – A-910-2.4ZB Radio Utility.....	44
Pre-installing the Common USB Port Driver.....	44
Installing the A-910 Utility Software.....	44
Manually Selecting the COM Port.....	46
Appendix J – Installing the A-1519 Light Shield.....	47

A-1519-2.4XBE/A-1520-2.4XBE Wireless Targets - Overview

The A-1519-2.4XBE/A-1519-2.4ZB and the A-1520-2.4ZB/A-1520-2.4XBE Wireless Targets incorporate new features and provide greater capabilities than previous wireless targets offered by Hamar Laser. New features include:

- Built-in radio transceiver, available in either 900 MHz or 2.4GHz ISM band
- Internal Li-Polymer rechargeable battery with twice the capacity of previously offered targets
- Rechargeable through a plug-in power supply or an optional charging station/cradle
- Field-Programmability: System ID and Target Network ID programmable via rotary DIP switches. Firmware Updates, Calibration and Other Parameters configurable through the USB Port, using the A-1519/1520 Configuration Utility.
- Three data communication modes: Wireless (Radio), RS-485 and USB
- Auxiliary Port for future expansion, such as a numerical display or external temperature sensor
- Improved Background light noise suppression
- Internal dampening by averaging of 2 to 64 laser position scans

Identifying Target Features



(1) Right Side Auxiliary Ports	(2) Front View	(3) Left Side ID Switches	(4) Rear View
<p>1-1 Auxiliary Port. Expansion Port.</p> <p>1-2 USB Port. Used to update target firmware, upload calibration data, configure operating parameters and run diagnostics. Can also be used as a Data I/O port, compatible with standard applications.</p>	<p>2-1 Target Status LEDs. <i>Steady</i> when the laser scanner is detected and all conditions are normal. <i>Blinks</i> at different rates when an abnormal condition is detected.</p> <p>2-2 Battery Charging Indicator.</p> <p>2-3 Low Battery Indicator.</p> <p>2-4 Position Sensor Aperture Window.</p> <p>2-5 Optional Light Shield Mounting Holes (4x).</p>	<p>3-1 System ID rotary switch used to set the System ID Group Number 0-9.</p> <p>3-2 Target Network ID. Used to set the Target Network ID from 01 to 99.</p>	<p>4-1 Radio regulatory information.</p> <p>4-2 RS-488 and plug-in power supply connector.</p> <p>4-3 Serial Number Label.</p>

Figure 1 – Target Features Chart

Managing the A-1519/A-1520 Battery Capacity

The Radio Transceiver Module built into the targets draws a significant amount of power from the internal battery, particularly when it is transmitting data. To conserve the battery, it is important that the Data Polling Rate (the number of data requests per second) is as infrequent as possible.

The following plot shows the battery discharge rate of an A-1519-900 Target (A-1519 with 900 MHz radio transceiver). With a Data Polling Rate of two samples per second, the target can be used for at least 10 hours. Increasing the Data Polling Rate to the fastest rate of three samples per second reduces battery life by approximately 10 percent.

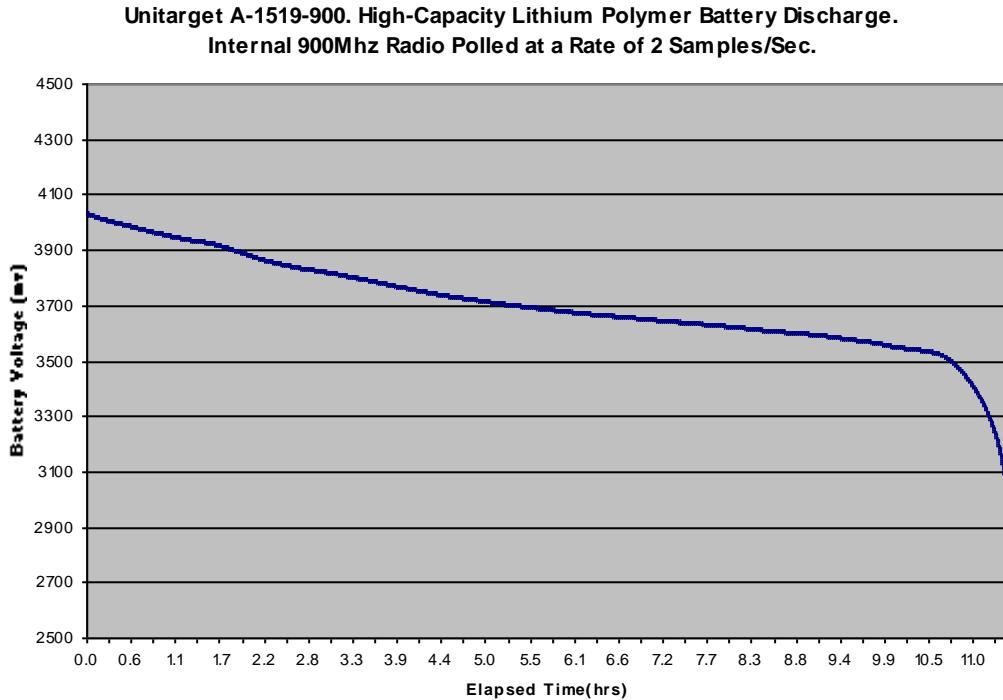

Note: The shelf life of lithium polymer batteries is 2-3 years under optimal conditions. Expect the battery capacity to drop to 80 percent after 500 charge/discharge cycles. To extend battery life, keep it away from heat (for example, inside a closed vehicle in full sun) and for best results, charge the battery to 100 percent of capacity and then allow it to discharge to 20 percent of capacity before recharging. Hamar Laser recommends replacing the internal battery every 10-12 months if the target is used daily for at least eight hours.

Resetting the Target

A target may be reset if it “freezes up” (LEDs don’t blink and the target does not shut down even when the laser is not powered on) by inserting the tip of a bent paper clip into the small hole shown in Figure 2.



Figure 2 – Reset hole for target

Connecting and Configuring the A-910 Radio Transceiver/R-1307 Readout

The Model R-1307 Readout

The Model R-1307 Readouts support both wireless, such as the A-1519, or cabled (local) targets. The wide choice of configurations (R-1307C, R-1307-900/2.4, R-1307-2.4ZB, R-1307-2.4XBE, R-1307W-900/2.4, R-1307W-2.4ZB and R-1307W-2.4XBE) is designed to suit a user's specific needs, with the R-1307-2.4ZB/ and the R-1307W-2.4 ZB models featuring ZigBee® radio technology. The latest radio technology being the XBee®

The readout is available with a radio frequency of either 900 MHz or 2.4 GHz and can be used as the *primary* readout or as an additional readout to copy position data captured by another R-1307.



Figure 3 – R-1307 Readout

R-1307 Control Panel

Figure 4 shows the features of the R-1307 Control Panel.

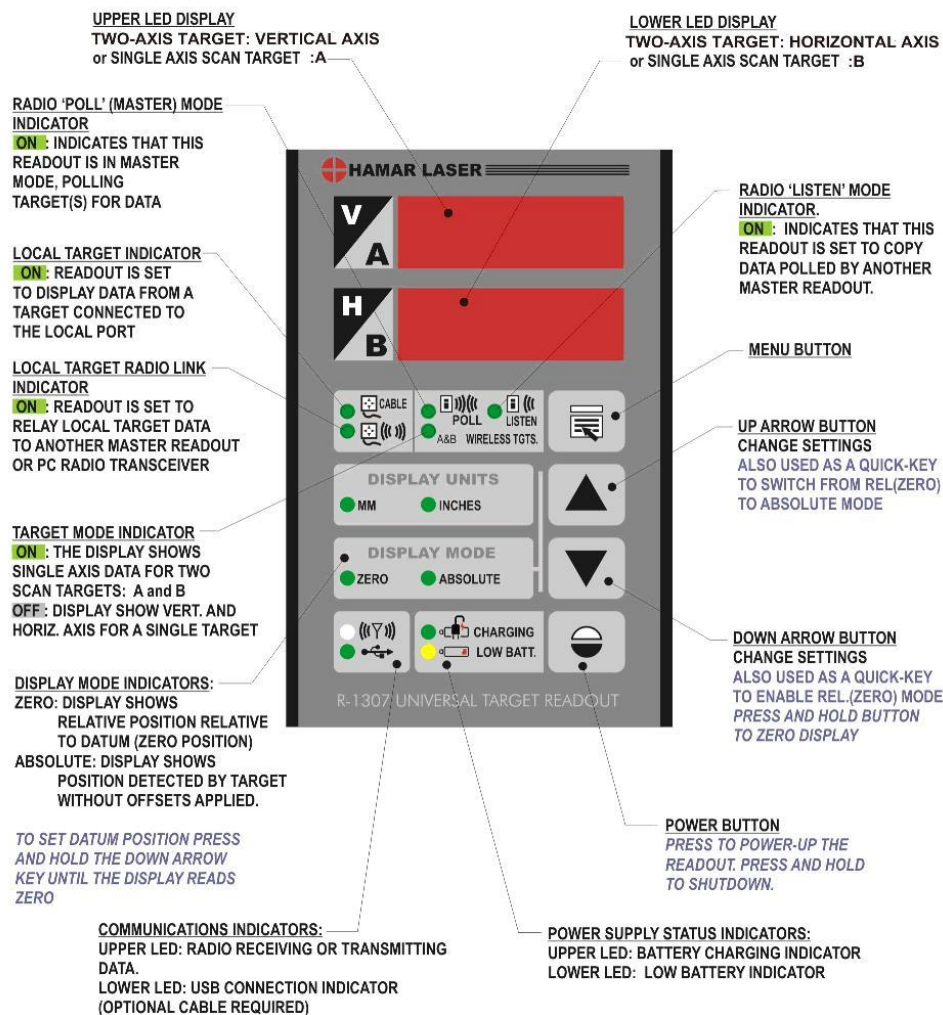

Figure 4 -- R-1307 Readout Control Panel Features

The A-910 Radio Transceiver/Hub

Front Panel Features

1. **Power ON indicator and Low Battery indicator**
2. **Internal backup battery charging indicator and USB LINK ESTABLISHED indicator**
3. **TX indicator:** blinks when device is transmitting data to the target(s)
4. **RX indicator:** blinks when the device is receiving data from targets or other transceivers.
5. **System ID setting switch:** set to the same number as the R-1307's CH (Channel) number.



Figure 5 – The A-910 Radio Transceiver/Hub FRONT PANEL

Rear Panel Features

1. **Not used**
2. **USB/Data I/O Port**
3. **Power Switch**
4. **External power supply:** required only for computers that cannot provide adequate power (5V, 400 mA) through the USB port.
Note: When using the USB Extender™ cable extension kit, plug the A-910-2.4 into an A/C power supply.
5. **Antenna**



Figure 6 – The A-910 Radio Transceiver/Hub REAR PANEL

See Appendix C on Page 29 for radio specification details.

<u>MODEL NUMBER</u>	<u>PRIMARY FREQUENCY</u>
A-910-900	900 MHz
A-910-2.4	2.4 GHz

Setting up the A-910 Transceiver

Note: Do not plug the A-910 USB cable into your computer until Step 3. Doing so may cause computer lockup.

1. Using the CD provided, install the USB Common Driver.
2. Using a small screwdriver, change the System ID on the front panel of the A-910 to 1.
3. Connect the USB cable to the back of the A-910 and to the USB port of your desktop or laptop computer.

The A-910-2.4ZB/A-910-2.4XBE and Utility Software

The A-910-2.4 ZB/A-910-2.4XBE operates with the R-1307-2.4ZB/R-1307-2.4XBE models and plugs directly into any unused computer USB port to communicate directly with the targets. Utility software is provided for driver installation, setup and configuration. For detailed information, see Appendix I beginning on Page 44.



Configuring the R-1307 for a Local Target

Note: Shut off power to the readout before connecting or disconnecting a target from the local port.

1. **Connect the cabled target to the local port of the readout**
2. **Press and hold the MENU button for approximately 2 seconds to enter configuration mode.**
3. **Set the Measurement Units**

Press the MENU button until the upper display shows $UNITS$. Use the UP and DOWN arrow keys to select either $INCH$ for inches or MM for millimeters.

4. **Set the Dampening Level**

Press the MENU button until the upper display shows $AVER$. Use the UP and DOWN arrow keys to set the number of averages. Adjust this value as required to suit the application. The default for this application should be changed to at least 8. For long distance shots, use 16 or 32.

5. **Set the Readout Function to Local Target**

Press the MENU button until the upper display shows $FUNCTION$. Use the UP and DOWN arrow keys to select $FUNCTION: LOCAL$.

6. **Select the PSD descriptor applicable to your target**

Press the MENU button until the upper display shows $TGT=nn$, where nn designates the target number. Each R-1307 has three target descriptors:

- TGT=0 (for HLI use only. Do not use)
- TGT = nn, P.10.10 (pulsed beam mode)
- TGT = nn, F.10.10 (fixed beam mode)

nn= R-1037 Readout number and Matching Target number

Press the UP or DOWN arrow to select the correct target number and to change the second window. For example, $TGT=02 F. 10. 10$ or $TGT=02 P. 10. 10$ for R-1307 #2

WARNING: Targets are matched to specific R-1307 Readouts. For example, Target #1 must be connected to Readout #1 or the calibration is void.

7. **To exit configuration mode, press and hold the MENU button for approximately three seconds until the display returns to normal mode.**

The R-1307 will also return to normal mode automatically after approximately four seconds of inactivity.

Setting the Target Network ID and System ID for the R-1307 Readout

To make the unit visible to all other radio-enabled devices, you must set the Target Network ID and the System ID for the readout.

1. Set the Local Readout/Target Network ID

Press the MENU button until the *upper* display shows *id = nn* (nn is also equal to the R-1037 number) and the matching Target number with the current Target ID (nn) blinking. Use the UP and DOWN arrow keys to set the Target ID.

Press the MENU button again until the *lower* display shows *id = nn* with the current Target ID (nn) blinking. Use the UP and DOWN arrow keys to set the Target ID to the same value as that of the upper display's Target ID.

2. Set the System ID (Radio Channel)

Press the MENU button until the upper display shows *ch = nn*, with the current System ID (nn) blinking. Use the UP and DOWN arrow keys to set the System ID. Note that **nn** must be set to the same number as the channel switch setting of the A-910 radio transceiver (see Figure 5 , #5).

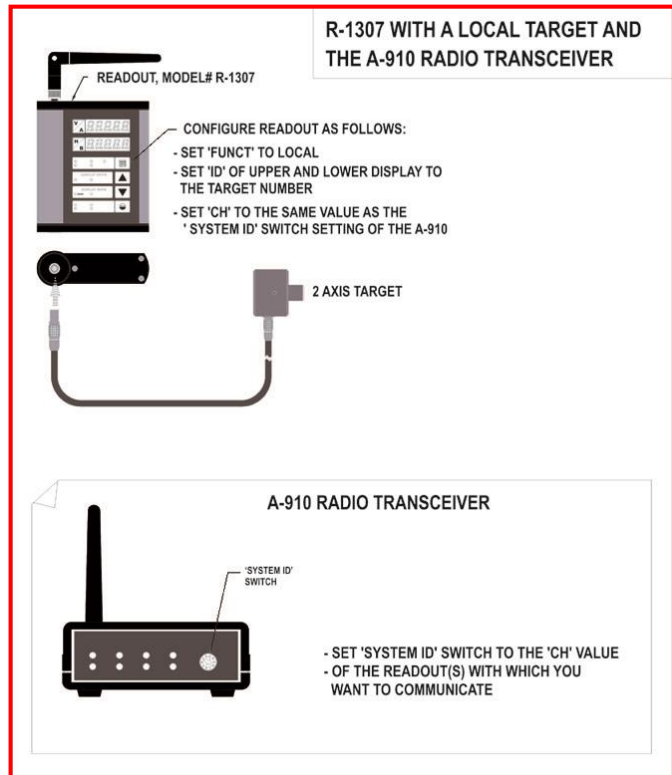

Figure 7 -- R-1307 with Local Target and A-910 Radio Transceiver

Miscellaneous Display Messages

-HLI-

r 1 00

...

- - -

ch = nn

rAd id

FAULT

PSd

tSt_n

UnCAL

Startup Message. Lower Display shows firmware Revision Number.

3 moving dots. Wireless target is not responding to a polling request from Readout. Check ID and Channel settings. Check Target(s).

3 dashes. Target detected but the laser is not on target. Check laser.

Radio channel cannot be selected because no Radio is present or detected.

Standard message for R-1307C. For Models R-1307 or R-1307W, this message indicates a fault in the radio module.

Indicates a problem with the connection to the Local Target's Position Sensing Device (PSD). Check plugs and cable(s).

Target 'n' descriptor does not contain target calibration data.

Wireless Communications Setup

Configuring the A-1519/1520 Target System Group

A Target System Group consists of one Radio Transceiver/Hub and up to 99 Type II Targets. There can be up to ten Target System Groups consisting of 99 targets per group.

To configure multiple targets and one Radio Transceiver as a System Group:

1. Set all targets to the same System ID, ranging from 1 to 9.
2. Set each target in the System Group to a different Target Network ID, ranging from 01 to 99 (Target Network ID: 00 is reserved for factory use).
3. Set the Radio Transceiver to the same System ID as the Targets in the same System Group.



Set the target System ID to the Radio Transceiver System ID

Figure 8 – Radio Transceiver and Target System ID

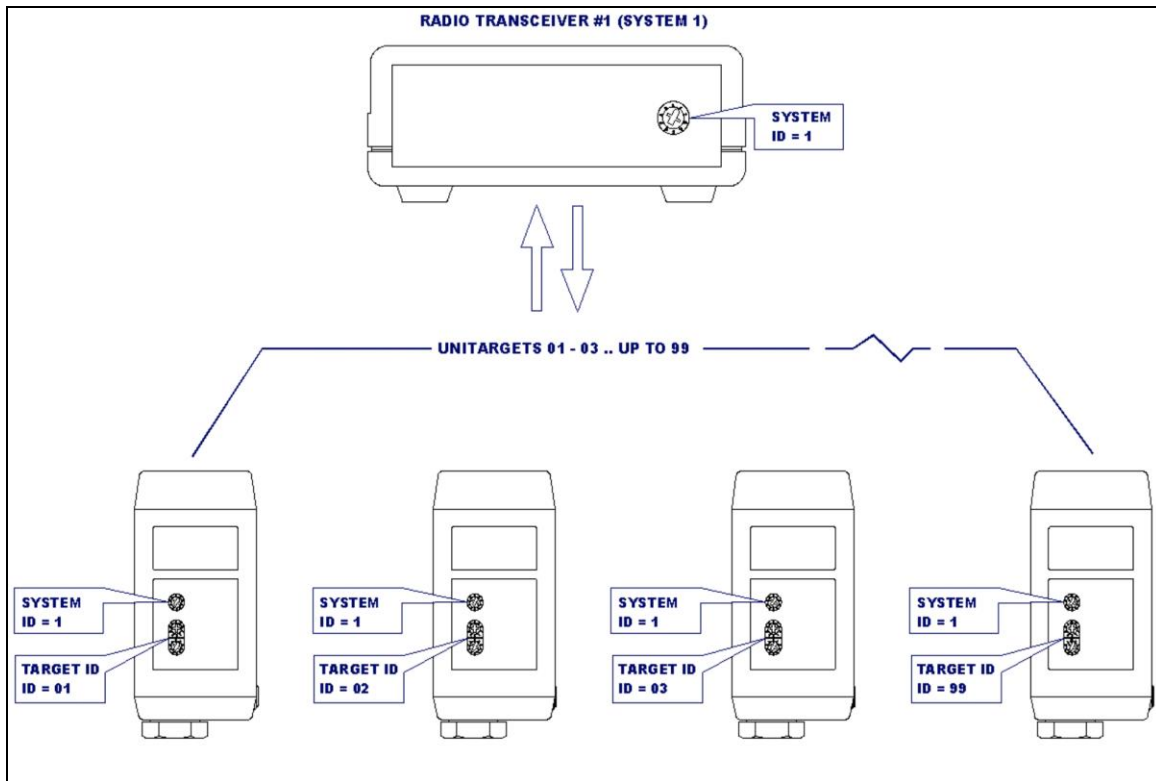

Figure 9 – Target System (System ID: 1) with 4 targets (Target Network ID: 01 to 03 and 99)

Setting the Target System ID and Target Network ID (A-1519/A-1520 Targets, A-910-900/2.4, A-910-2.4ZB/A-910-2.4XBE)

The System ID is a Radio Network Address that is used by the Radio Communications Protocol to filter unwanted data from other radio transceivers and targets using a different address. Only targets and radio transceivers that are set to a matching System ID can communicate with each other.

Because no two targets with the same System ID can transmit simultaneously, it is necessary for each target to be programmed to respond only when it is being addressed. The Target Network ID is the target address on the communications network. Under Host (computer) control, the radio transceiver transmits a message called a *polling request* that contains the Target Network ID of one specific target. All targets receive all polling requests, but only the target with a Network ID matching the ID contained in the polling message will reply (Transmit Data to the Host).

There are three rotary DIP switches located on the right side of the target, shown in Figure 10:

- The uppermost switch sets the System ID.
- The two lower switches are used to set the target network ID.

Setting the System ID

Note: Before selecting a System ID, ensure that it is not already in use by another system within the radio coverage area.

Using a small screwdriver, rotate Switch 1 to align the arrowhead with the System ID number (0-9). Figure 10 shows the System ID switch set to 1.



Figure 10 – Unitarget ID Switch set to 1

Installing and Using the Wall-Mounted Charging Station

The Wall-Mounted Charging Station is designed to accommodate A-1519/1520 Targets, with or without attached extension rods of up to .65 in diameter. When choosing a mounting location, ensure that you provide sufficient clearance above and below the mounting location to allow for easy removal and placement.

1. Mount the Charging Station to the wall or any other suitable vertical support structure using two screws of the appropriate type for the mounting structure (refer to Figure 11 and for dimensional information).
2. Plug in the Charging Station power supply.
3. To charge the Targets, place each target in one of the four cradles. Slide the target down until it is fully seated and the charging LED lights (see Figure 1, Front View, for the location of the Charging LED).

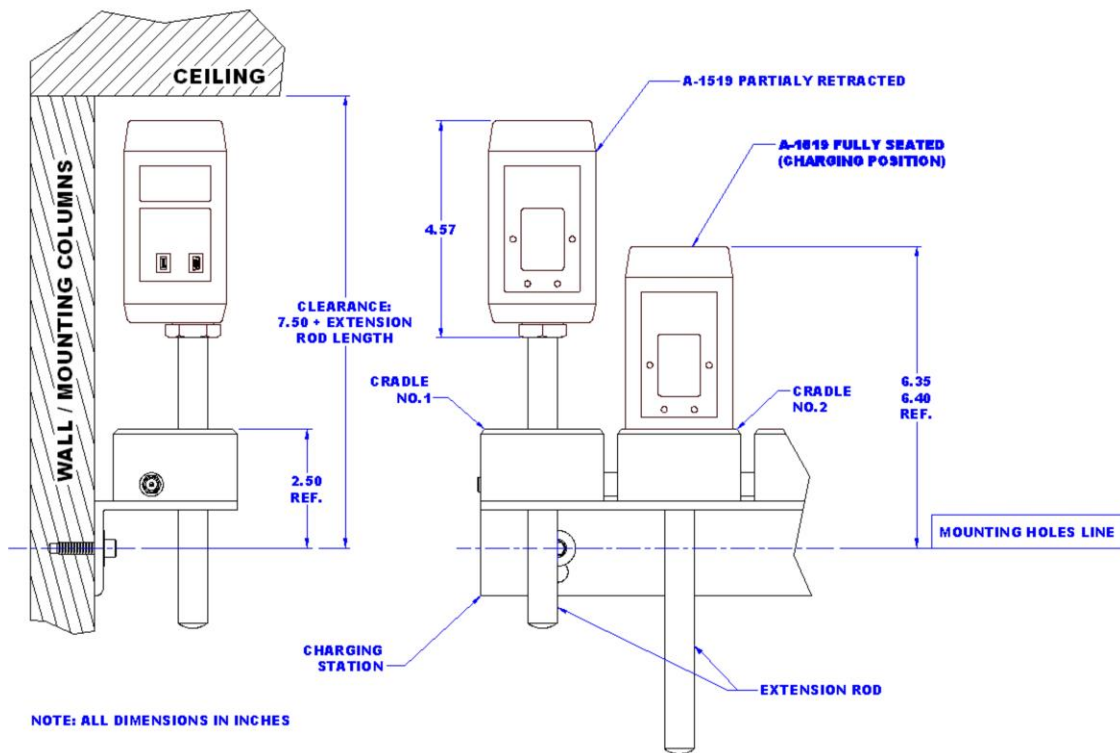

Figure 11 – A-1519/1520 on Charging Station

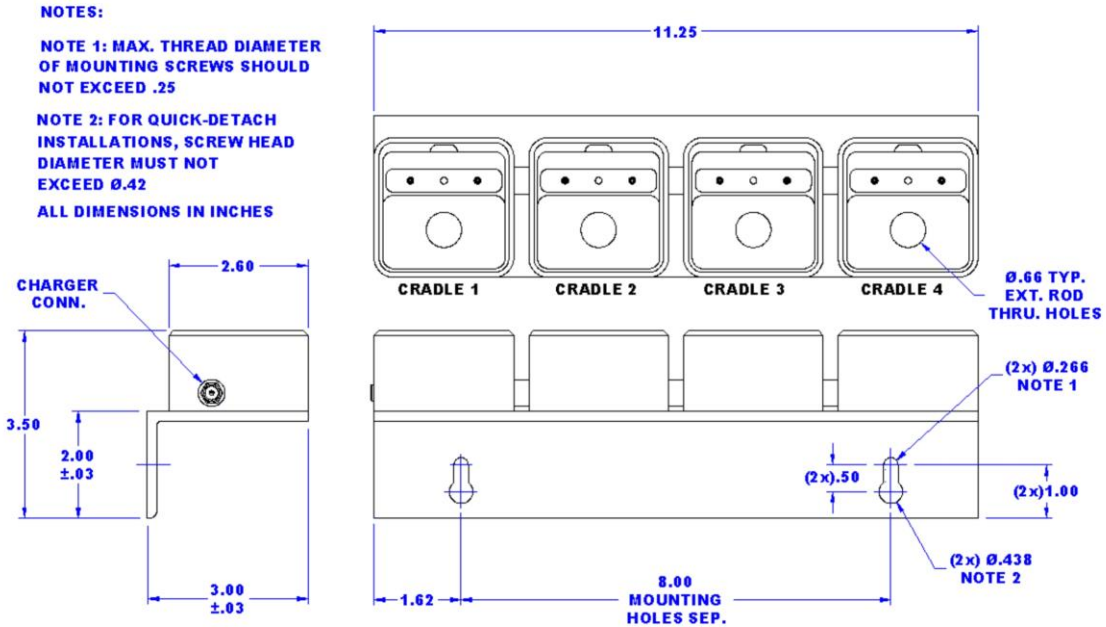

Figure 12 – Four position wall-mounted charging station

Charger Specifications

Power Supply	<i>Use only the included Hamar Laser power supply. Use of another power supply may void the warranty of the Charging Station and targets.</i> Input: 120VAC 60Hz (US) Output: 7.5VDC, 2A
Charging Rate	400mAH / Cradle / Target Maximum
Protection	Short circuit and reverse polarity protection
Explosive Atmosphere	Not approved

Software Installation and Configuration

WARNING!

- Ensure that all drivers are installed *before* installing the alignment software.
- The Configuration Utility is designed to be used with a USB cable *only*. Do not attempt to upload firmware or make configuration changes wirelessly. Doing so could damage the target.

Pre-installing the Common USB Port Driver (A-1519/1520 and A-910)

This driver is required for the A-910 Transceiver, the A-1519/1520 Configuration Utility and to communicate with targets via the computer's USB port. The driver creates a virtual COM Port that is recognized by the applications as a standard serial port.

Note: You must pre-install this driver prior to connecting the device(s) to the computer through the USB port. The Configuration Utility requires this type of connection.

Installing the Driver

1. Insert the flash drive into the target computer.
2. Open the flash drive and locate the driver installation executable (e.g., CP210xVCPInstaller.exe).
3. Double-click the executable to run the installer..

Follow the on-screen instructions to complete the installation..



Figure 13 – *Install Driver Dialog Box*

Installing and Using the A-1519/1520 Type II Configuration Utility

The Configuration Utility is not required for normal operation. Hamar Laser pre-configures the targets with operating parameters that are suitable for most applications. The Configuration Utility is used for the following functions:

- Firmware (Microprocessor program) Updates
- Calibration Data Table Uploading (normally done by Hamar Laser. A Calibration Station is required)
- Configuration of Internal Dampening Mode (Averaging)
- Configuration of Background Light Periodicity Sync Frequency (50Hz/60Hz AC power line frequency)
- Checking Firmware/Memory Status
- Diagnostic Readout

Installation

1. Insert the flash drive into the target computer
2. Open the flash drive and locate the Configuration Utility folder.
3. Click the **Setup** icon to install the utility.
4. Follow the screen prompts and select the defaults. If prompted to replace existing files, always keep the newest files.
5. After Setup completes, click **Start>Program Files>Hamar Laser Utilities**. Click **A-1519 Type II Configuration Utility** to start the program.

Users Database

The Configuration Utility uses a user database to assign permission levels to multiple users. Users must log in with a user name and password to configure the target, update firmware, etc. The person designated as the Primary Administrator on the computer should perform the initial software setup. The Primary Administrator has permission to add or remove users.

Initial Setup

Start the Configuration Utility Application. If it is the first time the application is initialized and a user database is not present, you will be asked to log in as a temporary user with administrator privileges. This temporary account is used to create the user database. Once the user database is created, the temporary account is deactivated.

Enter the following:

User Name: **hamarlaser** (not case sensitive)
Password: **hamarlaser** (case sensitive)

After entering the correct user name and password, the **Users** button is enabled (see Figure 14). Click on the **Users** button.



Figure 14 – Initial Login Window showing access to User Database granted

Editing the User Database

Upon initialization, the Users Database is blank and a *Primary Administrator* account must be created. *Additional Users* with three different permission levels may also be entered. Click **Show Passwords** to make the passwords visible on the screen as they are entered into the database (see Figure 15).

Permission Levels are as follows:

- **Primary Administrator** (single account)
This user has access to all program features and has permission to add and remove users.
- **Backup Administrator**
This user has the same access to program features as the Primary Administrator. Has permission to add and remove *Additional Users* only. Backup Administrators cannot make changes to the Primary Administrator account.
- **Power User**
This user can access to all program features, but does not have permission to access the Users Database.
- **Operator**
This user has access to basic configuration features but does not have permission to **Update Firmware** or **Calibration Data and Critical Configuration** parameters.
- **User Not in Database**
This user has access to **Target Status** and **Diagnostic Readout** only.

To edit the Users Database:

1. Enter the Primary Administrator's User Name and Password (twice)
2. Enter any Additional User Accounts as needed.
3. Click **SAVE** when you are finished adding users.

Figure 16 provides an example of five user accounts, including one Primary Administrator, one Backup Administrator, one Power User and two operators.

Figure 15 – Users Database – Initialization

Figure 16 – Example of Users Database with 5 User Accounts

Logging In



Figure 17 – The Login Button

1. Click the **LOGIN** button (the following information refers to the sample Users Database shown in Figure 16).
2. Enter User Name (shown in Figure 16 as **Admin2**).
3. Enter the password for this user.
4. Click **OK**. The **LOGIN** button changes to **LOGOUT** (see Figure 20). If you log in with Administrator privileges, always click on the LOGOUT button or close the application when you are finished using it.



Figure 18 – The Login Window

When a User Name is entered that exists in the Users Database and a valid password for that user, the **OK** button is enabled to indicate that the password is valid. Note that the **Users** button is also enabled because user **Admin2** is a Backup Administrator with permission to edit the Users Database.

To have the application remember your User Name and password for future login, check **Remember Password** (see Figure 19). *Do not check Remember Password* when logging in with Administrator privileges because any user logging in afterward will have access to the Users Database.



Figure 19 – Login Window with password validated



Figure 20 – The LOGIN button changes to LOGOUT after successfully logging in to the program

Startup

After the initial setup, you will be prompted to Scan COM Ports for Targets each time the Configuration Utility runs (see Figure 21). Do not click **YES** until the target is connected to the computer and powered on by a scanning laser.



Figure 21 – Auto-scan for targets

When a target is detected, one of the following messages displays.

Target Connected in Configuration Mode (Figure 22)

The target must be in Configuration Mode to perform the following functions:

- Firmware updates
- Change configuration parameters
- Change application mode

When a target is in Configuration Mode, the status LEDs (see Figure 1, Front View) blink slowly, approximately once every three seconds.

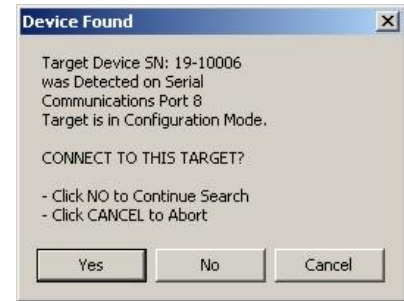

Figure 22 – Target detected in Configuration Mode

Target Connected in Application Mode (Figure 23)

The target must be in Application Mode to be used with standard applications that require position information in standard packet format. In addition, Diagnostic Readout is only functional in Application Mode.

When the target is in Application Mode, the Status LEDs (see Figure 1, Front View) will be lit continuously.

If a target is detected in Application Mode, you may also receive a message stating the Configuration Mode is not active (see Figure 24). Match the Serial Number shown in either message with the Serial Number on the target label. Click **YES** if the numbers match; click **NO** to search for other targets.



Figure 23 – Target detected in Application Mode



Figure 24 – “Not in Configuration Mode” notification

If the Configuration Utility fails to detect the target, the NO DEVICES FOUND message box displays (see Figure 25).

Note: Normally a target should be present in one of the first 16 ports. Occasionally, however, particularly if you are connected through a USB Hub, Windows will assign a virtual COM Port number higher than 32.



Figure 25 – Target Not Detected

Click **YES** to continue searching for target(s) on higher port numbers. Click **NO** if you are sure that the target is connected to a port number within the range of the port numbers shown in the message box (see Figure 25).

Troubleshooting

If you are sure that the target is connected to a port number within the range of the port numbers displayed in Figure 25, check the following:

- Is the USB driver installed? If not, refer to the section titled *Pre-installing the Common USB Port Driver (A-1519/1520 and A-910)* SiLabs CP210x USB to UART Bridge Controller on Page 12.
- Ensure that the target USB cable connectors are fully inserted into the computer and target.
- Ensure that the target is ON. The center LEDs (see Figure 1, Front View 2-1) should be lit continuously if the target is in Application Mode or blinking once every three seconds if the target is in Configuration Mode.
- Ensure that the laser is ON and scanning across the position sensor (see Figure 1, Front View 2-4).
- Click the **SCAN PORTS** button to rescan the ports (see Figure 20).

Switching Between Normal Application Mode and Configuration Mode

If the target is in Application Mode:

From the Target Mode Menu, select **Reboot to Configuration Mode** (see Figure 26).

If the Target is in Configuration Mode:

From the Target Mode Menu, select **Set to Normal Application Mode** (see Figure 27).

Note: If you log in with Power User or Administrator privileges, you may also select Non-Standard Mode(s) shown in Figure 30. Non-Standard Mode(s) is used for special functions, such as hardware debugging using the Diagnostic Readout. Remember to set the Target to Normal Application Mode before closing the Configuration Utility.

Click **System Reset** to force the target to power down and restart.

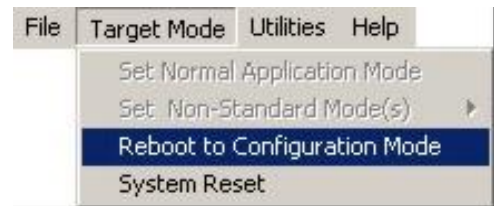

Figure 26 – Reboot to Configuration Mode

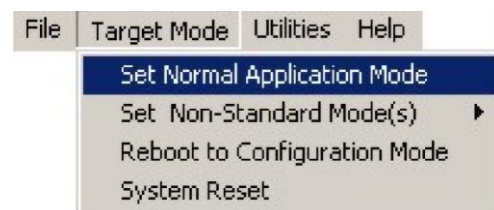

Figure 27 – Set Normal Application Mode

Diagnostic Readout – Normal Application Mode



Figure 28 – Menu Buttons for Normal Application Mode

1. Set the target to Normal Application Mode (see Figure 27).
2. When the menu buttons for Application Mode display, (see Figure 28) click **READOUT** to display the Diagnostic Readout window (see Figure 29).

Using the Diagnostic Readout Window

Top

- UNITS selection buttons (inches, millimeters or microns)
- To the right of the position display window:
 - _ The Periodicity Sync indicator
 - _ The Incident Light Level bar
 - _ The Battery Charge indicator.

Center

Packet data:

- Green fields indicate normal values
- Yellow fields indicate caution (values are borderline normal)
- Red fields indicate abnormal values

Bottom

- Communication Error Statistics
- Peak Noise (peak-to-peak) over the specified period
- Network ID of target being polled for data
- The polling interval
- External averaging
- Data saving (refer to *Diagnostic Readout – Advanced Functions* on Page 20).

Zeroing the Display

- To zero the live display, double click anywhere in the black display area.

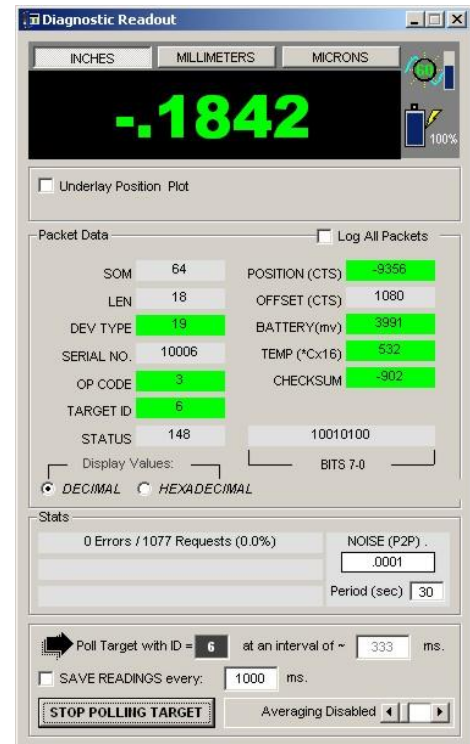

Figure 29 – Diagnostic Readout, Normal Application Mode

Diagnostic Readout – Debug Mode

In addition to the information displayed in the Application Mode Readout, the DEBUG Mode Readout also shows Raw Position Sensor readings, Power Supply Voltages, Beam-on-Sensor Time and Incident Noise Characteristics.

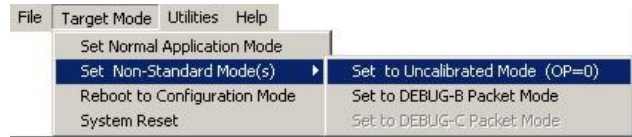

Figure 30 – Non-standard Modes

1. Set the target to DEBUG – B Packet Mode (see Figure 30). The Diagnostic Readout window displays (see Figure 31).
2. Click **START POLLING TARGET** (the button title changes to **STOP POLLING TARGET**).

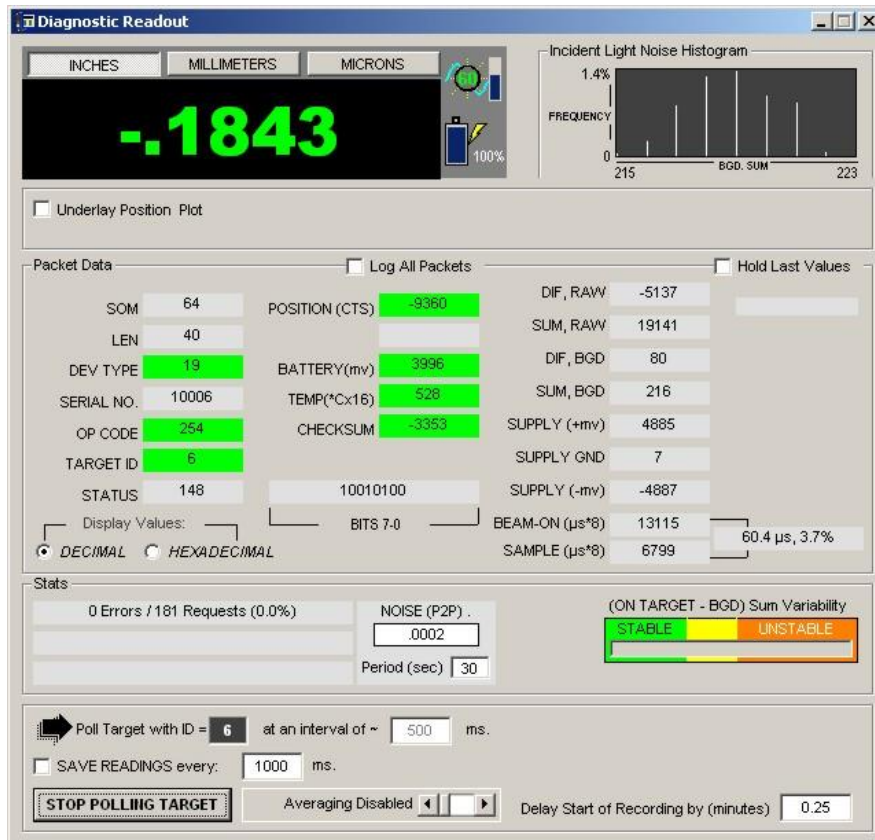

Figure 31 – Diagnostic Readout – Debug Mode

Diagnostic Readout – Advanced Functions

Saving Data (see Figure 31)

1. If the Readout is active, click **Stop Polling Target**. The button changes to **Start Polling Target**.
2. Check the **Save Readings every:** box and enter the save interval in milliseconds. This number must be greater than or equal to the polling interval.
3. Click **Start Polling Target**. The button changes to **Stop Polling Target**.
4. You will be asked to specify a location to save the file and a file name. If the file is saved with an **.xls** extension, you will be able to import the data directly into Microsoft Excel®.
5. Click **Stop Polling Target** to stop saving data.

Dynamic Plot

Check **Underlay Position Plot**. The position readings will plot behind the Numerical Position Display.

Plot Options:

- Check **Show Plot Only** to hide the numerical position.
- By default the plot will show 100 samples along the X-axis. The slide bar below **Underlay Position Plot** allows you to change the number of samples to plot.
- Check **Overlap Runs** to prevent the plot screen from being cleared every time the maximum number of samples is reached.
- Double-click on the plot area to clear and re-center the current position.

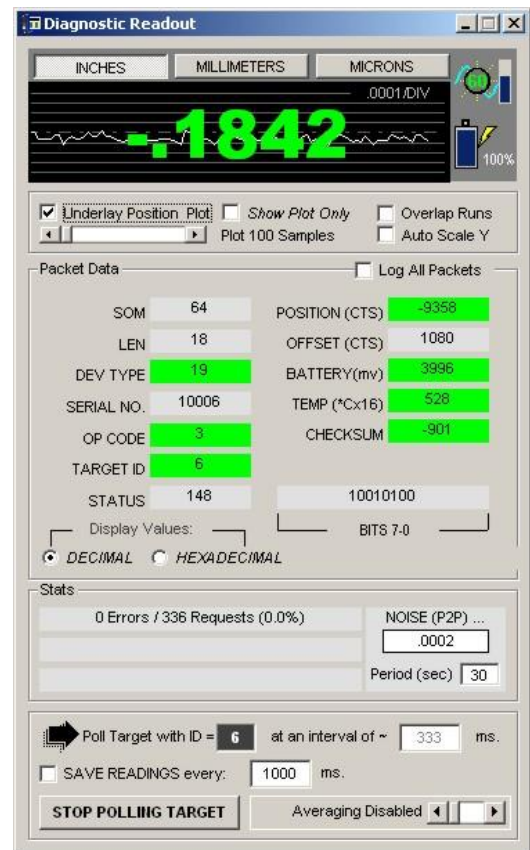

Figure 32 – Data Plot

Updating the Firmware

WARNING!

- **The Configuration Utility is designed to be used with a USB cable *only*. Do not attempt to upload firmware or make configuration changes wirelessly. Doing so could damage the target.**



Figure 33 – Menu Buttons in Configuration Mode

1. Log in with a Power User or Administrator access level.
2. If the target is in Application Mode, select **Reboot to Configuration Mode** as shown in Figure 26.
3. Wait for the utility to re-acquire the target.
4. Click **Firmware**. You will be prompted to locate the firmware file. Firmware update file names are prefixed with **A-1519/1520** and have an extension of **.hfw**. For example, firmware revision 7.35 would have a file name of **A-1519/1520_Firmware_V7_35.hfw**.
5. Locate the A-1519/1520 Type II firmware update file and click **OPEN**.
6. Wait for the utility to finish processing the file for uploading to the target (see Figure 35).

When the file processing completes, verify that you want to update the target firmware with the specified file version (see Figure 34). The firmware version that is presently installed in the target is shown in the Target Properties area of Figure 35. In that example, the target is using firmware version 7.033. Click **YES** to upload the new firmware version, or click **NO** if the file version is lower or the same as the target version.

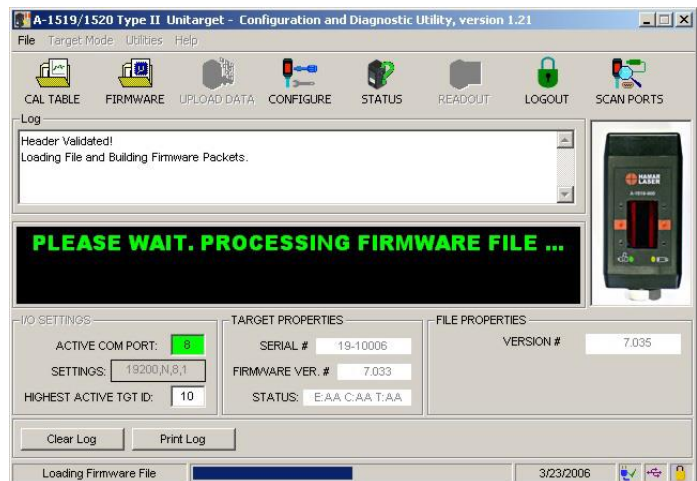

Figure 35 – Loading and preparing firmware file for upload to target



Figure 34 – File version upload confirmation

Do not disconnect the target while the firmware upload is in progress (see Figure 36).

When the upload completes, an EOF (End of File) verification message displays (see Figure 37). Click **OK**.

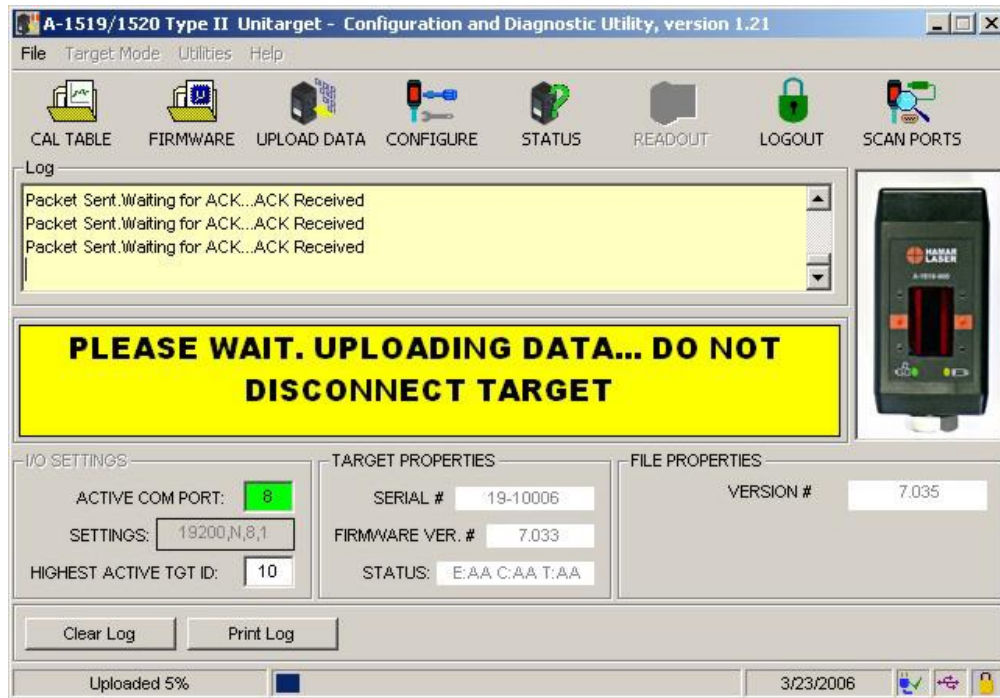

Figure 36 – Target firmware upload in progress



Figure 37 – End-of-File Verification message

Configuration Parameters

Note: To configure target parameters, you must be logged in as an Administrator or Power User.

Click the **CONFIGURE** menu button (see Figure 33).

The Target Configuration Window displays (see Figure 38). The following fields are disabled (reserved for Hamar Laser use only):

- Device type
- Serial
- V KFactor
- H KFactor
- Mfg. Date
- Cal. Station ID
- Cal
- Temp Compensation Factor
- PV Cell Scale Factor
- All Hardware Revision
- Radio

The screenshot shows the 'TARGET CONFIGURATION' window with the following fields and values:

Configurable Parameters			
DEVICE TYPE:	19	SERIAL:	11079
V KFACTOR:	30000	H KFACTOR:	13000
MFG. DATE:	02/04/10	CAL. DATE:	00/00/00
V CL OFFSET:	0	H CL OFFSET:	0
CAL. STATION ID:	001	CAL.:	0.0 °C
TEMP. COMPENSATION FACTOR:	0.00		
AC FILTER:	Light Periodicity Synchronization: 60/120Hz		
PV CELL SCALE FACTOR:	0.0 μm / °C		
AVG. SAMPLES:	Internal Average Enabled. Position = Average of 4 Samples		
BLINKS to OFF:	30 ~ sec		
AVG. MODE:	Normal Running Average of 'n' Samples		
VERT SUM THRESHOLD:	1500		
POS. SENSING:	Scan Target w/Dual Axis Sensor		
RADIO:	Hopping Freq. Sequence: CH0=1, CH1=2 ... (DEFAULT)		
Hardware Revision			
P.S.:	1519/120	REV.:	J
ANALOG PCB#:	1519/126	REV.:	E
DIGITAL PCB#:	1519/127	REV.:	B

Data Packet. Click **UPLOAD** to Program Target

Buttons: **LOAD FROM FILE**, **SAVE TO FILE**, **UPLOAD**

Figure 38 – Target Configuration Window

AC Filter

Light Periodicity Synchronization

This setting is used by the incident light noise compensation filter to minimize the effects of background light intensity fluctuations on the position sensor signal. The intensity of most light sources, such as fluorescent lighting, fluctuates at the AC line frequency or twice the AC line frequency.

Set the Light Periodicity to the AC line frequency at the location where the target will be used as follows:

- 60/120Hz (United States)
- 50/100Hz or 60/120Hz (other countries)

Note: DEBUG is for Hamar Laser use only.

Avg. Samples

Internal Average Enabled. Position = Average of Samples

Vibration and air turbulence may cause target position readings to become noisy. You may have to dampen the noise by averaging, particularly if the laser is far from the target. You may enable Target Internal Averaging or Disable Internal Averaging if your application performs that function.

If Internal Averaging is enabled, the position reported by the target is the moving average of the last n position samples. You may select 2, 4, 8, 16, 32, 64 scans.

Avg. Mode

- Normal Running Average of n Samples (Default)
- Reset Average if Position Change Exceeds STDEV (Standard Deviation)
- Reset Average if Position Change Exceeds 2*STDEV (2X Standard Deviation)
- Reset Average if Position Change Exceeds 4*STDEV (4X Standard Deviation)
- Reset Average if Position Change Exceeds 8*STDEV (8X Standard Deviation)
- Reset Average if Position Change Exceeds 4 μm (4 Microns)
- Reset Average if Position Change Exceeds 8 μm (8 Microns)
- Reset Average if Position Change Exceeds 16 μm (16 Microns)
- Reset Average if Position Change Exceeds 32 μm (32 Microns)
- Reset Average if Position Change Exceeds 64 μm (64 Microns)

Note: *Reset Position Modes should be used only for very stable environments.*

Pos. Sensing

The Unitarget utility is *not* compatible with the Type I (IR or radio) Unitargets. The utility is only intended for use with Type II A-1519 and A-1520 Unitargets. The Type II Unitargets have a USB and an AUX port on the left side of the target and a circular connector in the back. The Type I Unitarget is smaller and only has a single circular connector in the back.

There are two types of Type II Unitargets in the field. The A-1519 targets can be identified by the sensor type, visible through the front window as shown in Figure 39.

Type II-Legacy, Single Axis Sensor

- Compatible with radio version of the Type I Unitarget.
- Supports all scanning lasers.
- Does *not* support fixed (continuous) or pulsed line lasers.

Type II-Current Version, Dual Axis Sensor

- Supports all scanning lasers.
- Supports fixed (continuous) and pulsed line lasers.

Configure the target using the utility, based on the laser type and Type II Unitarget as follows:

Scanning, Single Axis Legacy Mode: Select this mode for Type II Legacy Targets *only*. Select for use with scanning lasers only.

Scanning, Dual Axis Mode: Select this mode for Type II, current version. Select for use with scanning lasers only.

Fixed Beam, Dual Axis: Select this mode for all continuous line lasers (for example the L-700 and L-705 in continuous mode).

Pulsed Beam, Dual Axis: Select this mode for use with pulsed line lasers only (for example, the L-705 in pulsed beam mode).

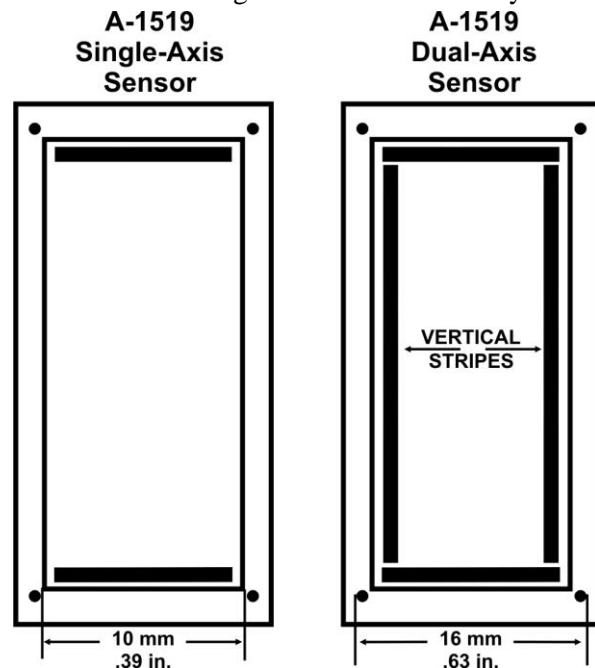
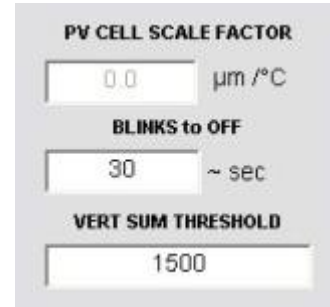

Figure 39 – A-1519 Single and Dual-Axis Sensors

Other Parameters

- **BLINKS to OFF:** Number of times that front LED's blink before target shuts down after it loses the laser beam. One blink equals approximately one second. The default is 30 seconds.
- **VERT SUM THRESHOLD:** Sets the background light level at which the target starts to shut down. By default, 1500 should be used. Only used for *fixed beam mode*.



The image shows a control panel with three rows of input fields. The first row is labeled 'PV CELL SCALE FACTOR' and contains a text box with '0.0' and the unit 'μm / °C'. The second row is labeled 'BLINKS to OFF' and contains a text box with '30' and the unit '~ sec'. The third row is labeled 'VERT SUM THRESHOLD' and contains a text box with '1500'.

Click **UPLOAD** to program the parameters into the target memory.

Calibration Table

The Calibration Table upload feature of this Utility is intended for customers who wish to develop their own in-house calibration system. Hamar Laser may, at our discretion, provide limited assistance regarding customer calibration procedures for the targets, however most assistance is limited to information regarding the structure of the calibration file.

Hamar Laser Calibration Method

The A-1519/A-1520 targets are calibrated using a proprietary, automated station designed by Hamar Laser. The calibration station is comprised of a precision motorized linear stage, using an interferometer as the position reference. Under computer control, the target is displaced from the highest position on the internal sensor to the lowest position, at very small intervals.

The target “raw” position is then compared to the interferometer position reference. The difference (error) is stored in a calibration table, uploaded to the target and stored in non-volatile memory. The target firmware uses this internal table to correct the “raw” sensor position readings. The same type of calibration station is used to verify the targets after the calibration table has been uploaded

Appendix A – Equipment Specifications

Type II Targets

General:	
Size:	2.00 in. W x 4.11 in. H x 1.75 in. D (50.8 mm x 104.4 mm x 44.5 mm)
Weight:	10.3 oz. (292 grams)
Target Angle Acceptance Range:	± 10°
Power Supply:	7.5-12vDC, 500mA
Operating Range:	100 ft. from laser to target
Spherical Tip Size:	.620 in. diameter x 2.565 in. long (15.75 mm x 65.15 mm)
Spherical Tip Weight:	3.2 oz. (90.7 grams)
Magnetic Base Size:	2.00 in. W x 3.09 in. H x 4.14 in. D (50.8 mm x 78.5 mm x 105.2 mm)
Magnetic Base Weight:	2.78 lb. (1.26 Kg)

Accuracy:			
Model Number	Sensor Resolution	Linearized Accuracy	Range
A-1519	0.00002 in. 0.0005 mm	0.00015 in. 0.0035 mm	1.0 in. 24 mm
A-1520	0.00001 in. 0.00025 mm	0.00006 in. 0.0015 mm	0.2 in. 5 mm

Range may be limited by obstructions, antenna type and orientation.
Outdoors line-of-sight range, with dipole antenna, may be greater.

Radio Specifications	<u>900 MHz Models</u> A-1519-900 A-1520-900	<u>2.4 GHz Models</u> A-1519-2.4 A-1520-2.4
Indoor Range	Up to 300 ft. (91 m)	Up to 600 ft. (183 m)
Transmit Power	4 mW	50 mW
Radio Frequency	902-928 MHz, Frequency Hopping	2.4000-2.4835 GHz, Frequency Hopping
Certification (see certification details)	FCC (US): OUR-9XCITE IC (CANADA): 4214A-9XCITE CE: Not approved	FCC (US): OUR-24XSTREAM IC (CANADA): 4214A 12008 CE: ETSI

Appendix B – Interpreting the A-1519/1520 Type II Calibration Reports

The A-1519-2.4 Target has a 0.5 micron resolution and 3.5 micron accuracy, versus the A-1520-2.4 Target, which has a 0.25 micron resolution and 1.5 micron accuracy. When the elevation of either target is set near zero (within ± 1 mm from zero), the most accurate part of the sensor is in use. The calibration graph on Page 28 shows that the error in the central part of the sensor for the A-1519-2.4 is less than 1 micron, which is better than the total error of the A-1520-2.4 (± 1.5 microns). Furthermore, when a target is zeroed on a given spot on the sensor for high-accuracy measurements (for example, measurement deviations of less than 25 microns), the error in the measurement from one point to the next is extremely small.

When a target is calibrated, measurements are taken every 1 mm and the error in between is interpolated. This makes it very likely that the error in measurement at the point where the target is zeroed is nearly identical to the error in each subsequent measurement because the difference in sensor area between the two points is less than 1 mm. So in effect the error really does not matter – it's like having the same error "offset" at each point. The errors start becoming important only when large deviations from zero are being measured, for example 1 mm or more.

The accuracy of the A-1519/A-1520 Type II targets is specified in the report below as an error of 3.2 microns (μm). This means that the maximum error of a given measurement could be $\pm 3.2 \mu\text{m}$ over the central 80 percent of the measuring area of the target.

For example, if one measurement point was at -12.5 mm (-.492 in.) and the next measurement point was +12.5 mm (+.492), then the maximum error in the 25 mm deviation would be no more than 6.4 μm (.00024 in.).

When measuring small deviations in flatness/straightness (less than .1 mm), the maximum error is much lower (usually about 1 micron or better). See the explanation of the graph below for more details.

HAMAR LASER INSTRUMENTS, INC - UniTarget® Calibration Certificate / Report

SERIAL NUMBER: **19-10499**
 Calibration Date: 12/3/2007

Position Detector Length (mm):	30.0 mm
Position Detector, Calibrated Range (mm)	± 12.7 mm
Output Resolution (microns)	0.5 μm
Accuracy Spec (within Calibrated Range)	3.8 μm , 0.00015 inches
Calibrated (measured) accuracy *	3.3 μm, 0.00013 inches

NOTE: This device complies with Hamar Laser specifications as of the date of this certificate. Hamar Laser reserves the right to make future improvements and change specifications without notice. Calibration Reference: Interferometer SN:G24358, Cal Cert #G24358-121206/1. Exp Date: Dec 2009

* Maximum error, within the central 80% of the position detector area.
 3.3 μm , 0.00033 mm, 0.00013 inches
 Linear Fit (Least Sqr): Slope=0.18750 $\mu\text{m}/\text{mm}$

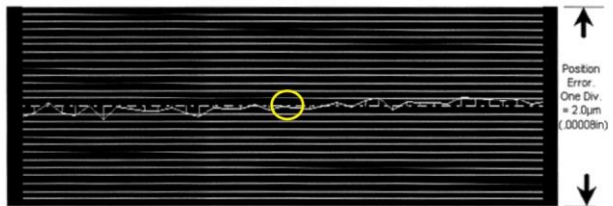

* NOTE: CALIBRATED WITH MASTER LASER #719-001

Target Temperature: 29.9 - 29.8°C
 Ambient Temperature: 21.1 - 21.1°C
 Relative Humidity: 25.8 - 25.8%
 Barometric Pressure: 981 - 980 mBar
 Dampening (n Samples): 10

File: H:\MFG_SOP\UniTarget\Calib\Verity\SN1910499-DEV19 12-3-2007 11(1).dot, Temp. drift - 0.1°C, E7-10

Total Error = +/- 3.3 microns

* Maximum error, within the central 80% of the position detector area:

3.3 μm , 0.0033 mm, .00013 inches

Linear Fit (Least Sqrs.): Slope=0.18750 $\mu\text{m}/\text{mm}$

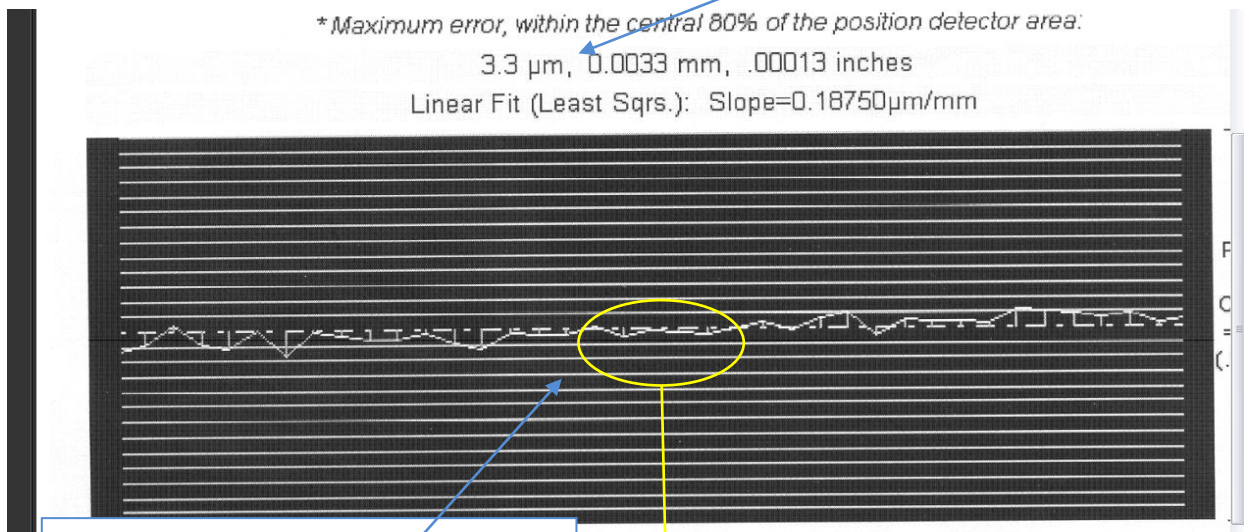

Approx. +/- 4 mm of measuring area – each vertical line on the graph equals 1 mm.

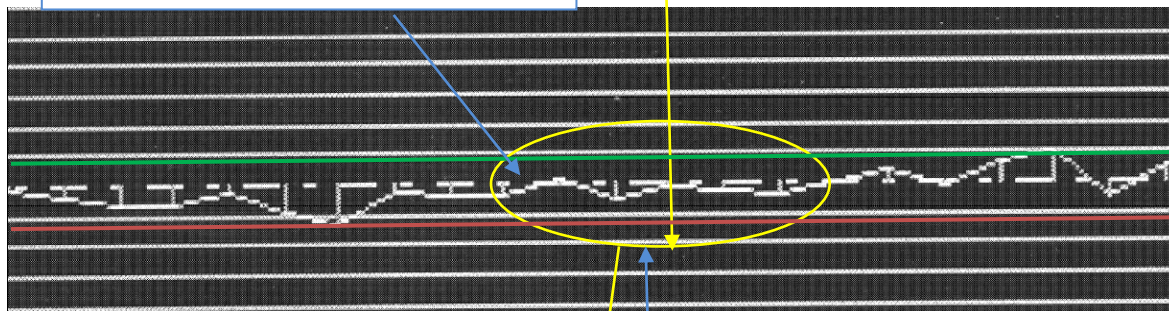

+ 2 microns

0.000

- 2 microns

Error in this area is 1 micron or less

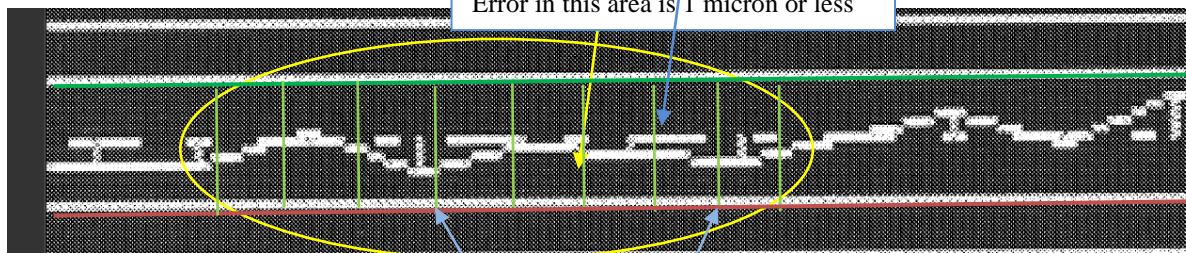

+ 2 microns

0.000

- 2 microns

Each green vertical line equals 1 mm of measuring area on the detector. The total area here is 8 mm.

Appendix C – Agency Certifications

Agency Certifications for the 2.4 GHz Radio Transceiver

FCC (United States of America) Certification

Contains FCC ID: OUR-24XSTREAM

The enclosed device complies with Part 15 of the FCC Rules. Operation is subject to the following two conditions: (1) this device may not cause harmful interference and (2) this device must accept any interference received, including interference that may cause undesired operation.



RF EXPOSURE WARNING: This equipment is approved only for mobile and base station transmitting devices, separation distances of (i) 20 centimeters or more for antennas with gains < 6 dBi or (ii) 2 meters or more for antennas with gains \geq 6 dBi should be maintained between the antenna of this device and nearby persons during operation. To ensure compliance, operation at distances closer than this is not recommended

IC (Industry Canada) Certification

Contains Model 24XStream Radio (2.4 GHz), IC: 4214A 12008
Complies with IC ICES-003



Complies with ETSI. *France – France imposes restrictions on the 2.4 GHz band. Go to www.art-telecom.fr or contact MaxStream* for more information. Norway – Norway prohibits operation near Ny-Alesund in Svalbard. More information can be found at the Norway Posts and Telecommunications site (www.npt.no).*

Since the 2.4 GHz band is not harmonized throughout Europe, other restrictions may apply to your country.

Technical Data:

- OEM radio transceiver, model number: 24XStream
- Frequency Band: 2400.0 – 2483.5 MHz
- Modulation: Frequency Shift Keying
- Channel Spacing: 400 kHz
- ITU Classification: 400KF1D
- Output Power: 100 mW EIRP max.
- Notified Body Number: 0891

* The radio Transceiver contained in the A-1519/A-1520 Type II Universal Wireless Targets is manufactured by MaxStream®. For more information pertaining exclusively to the Radio Transceiver please contact MaxStream at 1.801.765.9885 or visit their web site: <http://www.maxstream.net>

Agency Certifications for the 900 MHz Radio Transceiver

FCC (United States of America) Certification

Contains FCC ID: OUR-9XCITE

The enclosed device complies with Part 15 of the FCC Rules. Operation is subject to the following two conditions: (1) this device may not cause harmful interference and (2) this device must accept any interference received, including interference that may cause undesired operation.



RF EXPOSURE WARNING: This equipment is approved only for mobile and base station transmitting devices, separation distances of (i) 20 centimeters or more for antennas with gains < 6 dBi or (ii) 2 meters or more for antennas with gains \geq 6 dBi should be maintained between the antenna of this device and nearby persons during operation. To ensure compliance, operation at distances closer than this is not recommended

IC (Industry Canada) Certification

Contains Model 9XCite Radio (900 MHz), IC:4214A-9XCITE

Agency Certifications for the XBee® 802.15.4 Series 1

FCC (United States of America) Certification

Contains FCC ID: OUR-XBEE

The enclosed device complies with Part 15 of the FCC Rules. Operation is subject to the following two conditions: (1) this device may not cause harmful interference and (2) this device must accept any interference received, including interference that may cause undesired operation.



RF EXPOSURE WARNING: This equipment is approved only for mobile and base station transmitting devices, separation distances of (i) 20 centimeters or more for antennas with gains < 6 dBi or (ii) 2 meters or more for antennas with gains \geq 6 dBi should be maintained between the antenna of this device and nearby persons during operation. To ensure compliance, operation at distances closer than this is not recommended

IC (Industry Canada) Certification

Contains Model XBee 902.14.4 IC:4214A-XBEE



Complies with ETSI (Europe), C-TICK (Australia) and Telec (Japan)

Appendix D – Dimensional Drawings

A-1519 Type II Universal Wireless Target

(All dimensions in inches)

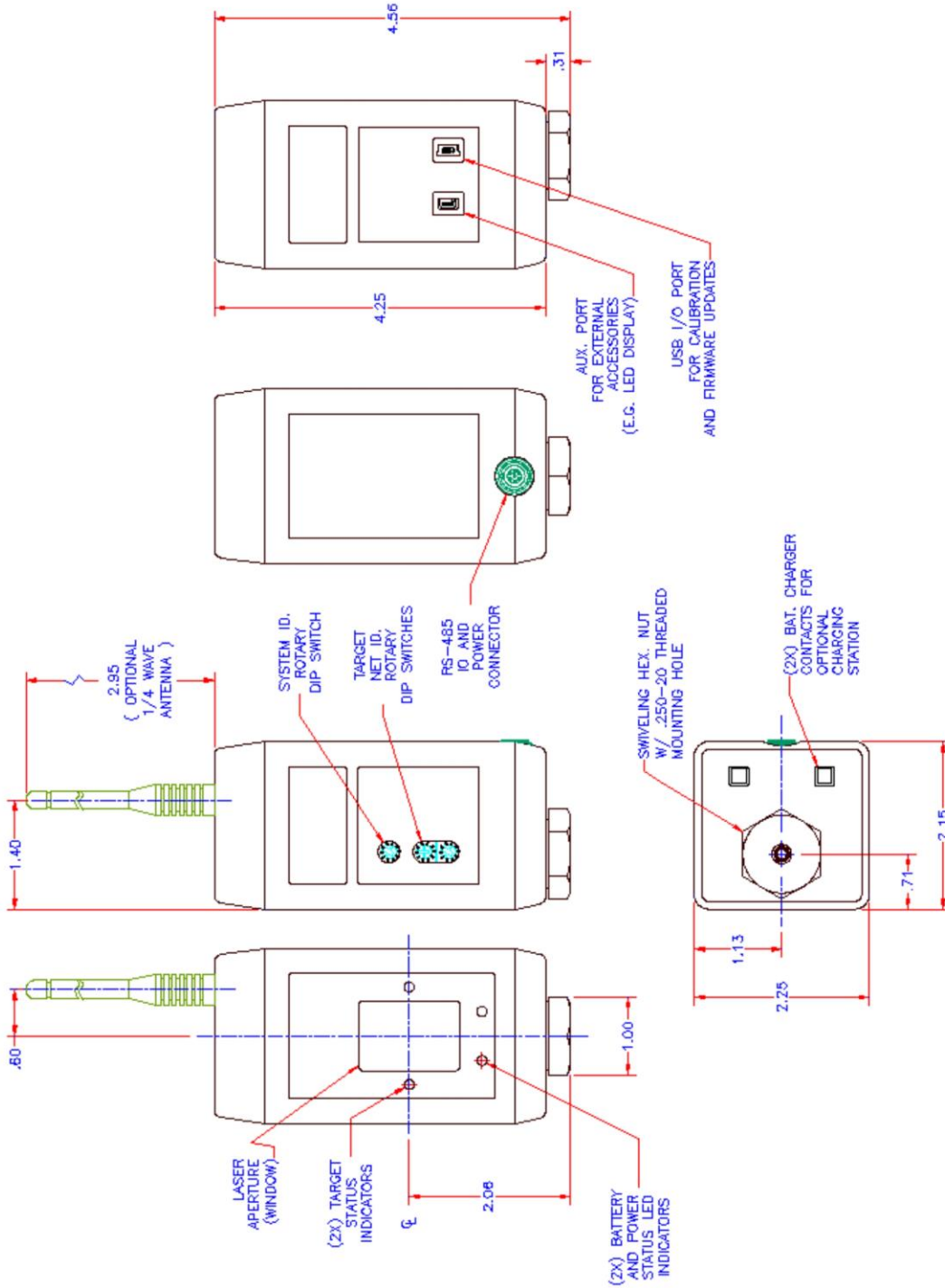

A-1519 RS-485 Cable Diagram

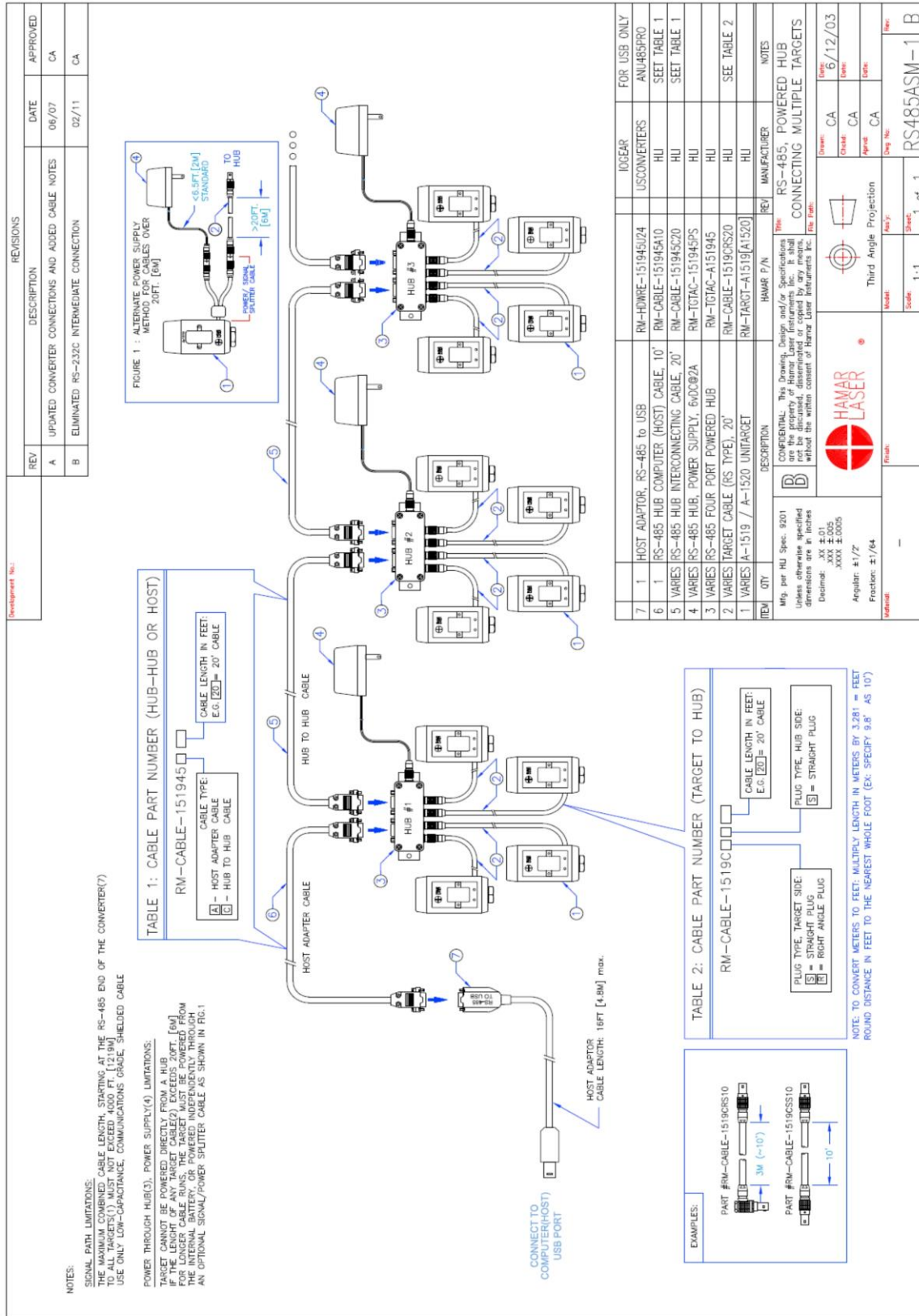

Appendix E – Using the A-151945 4-Port Target Communication Wired Hub

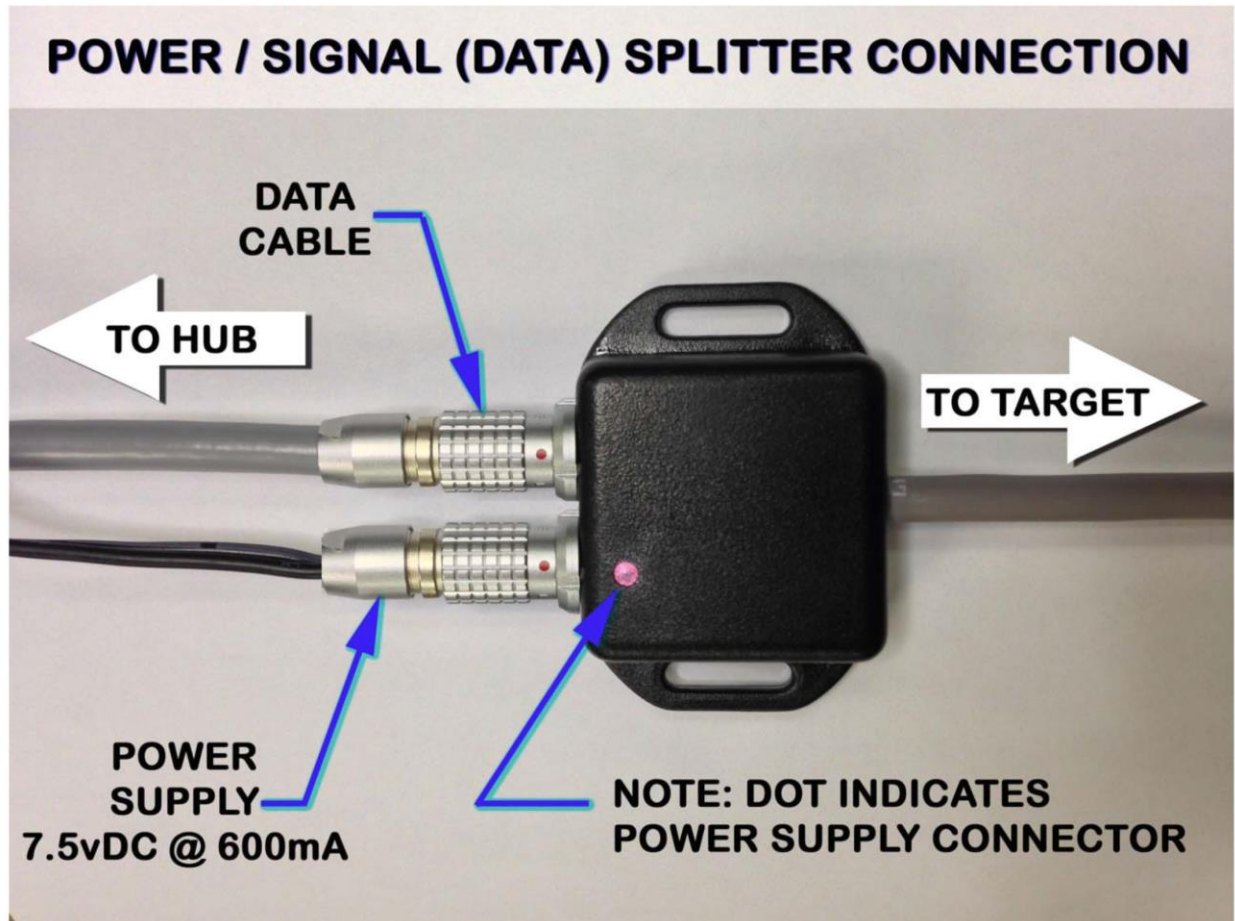

Appendix F – Programmer’s Reference

Polling the A-1519 and A-1520 Targets

The A-1519/A-1520 Targets do not transmit data until the Host Computer/Application transmits a polling request to each target that it needs to read. The polling request command consists of a Single Byte Code, equal to the Target Network ID.

For example: *To request a Data Packet from an A-1519 Target set to Target Network ID = 64, the host Application must transmit an ASCII 64 (40 hex).*

Polling interval by target data connection type:

- Wireless targets (ISM or ZigBee radio, 900 MHz and 2.4 GHz): 160 milliseconds or greater
- Cabled targets (RS-485 network): 70 milliseconds or greater.

Note: *The polling rate for scanning lasers (time interval between successive requests for data from the same target) should be greater than or equal to the scan rate. For most Hamar Laser scanning lasers, the recommended polling rate is 4 times/second (250 milliseconds interval). Polling the same target at a rate faster than the laser scan rate is pointless because the target will not reply with a new data packet until the position has been refreshed by a new laser scan.*

Standard procedure for polling a target:

- a) Initialize the Active COM Port with the following Settings:
 - 19200 baud
 - No Parity
 - 8-bit word
 - 1 Stop Bit
- b) Transmit the Single Byte Request Code = Target Network ID of the target that is being polled.
- c) Set a timeout: Wait a minimum of 60 ms for a reply. Radio I/O may require up to 160 ms.
- d) Process Data in the Input Buffer: Validate Checksum, Parse Data Packet, etc.
- e) Check Validity of Device Type, Operational Status Code, on-target status, etc.
- f) If polling another target, go to **Step a**.
- g) If polling the same target, wait until the polling interval has elapsed since **Step a** was executed, then go to **Step a**.

Normal Application Data Packet

Packet Length: 18 bytes (Including two Checksum bytes)

Byte 1	2	3	4	5	6	7	8	9	10	11	12	13	14	15	16	17	18
SOM	LEN	DEV	SN	OPC	TNI	TST	WP	VCO	BAT	TEMP	CHK						

	<u>DEC</u>	<u>NOTES</u>
SOM = START OF MESSAGE	64	
LEN = LENGTH OF MESSAGE	18	
DEV = DEVICE TYPE	19,20	<i>A-1519 = 19 DEC</i>
SN= SERIAL NUMBER	00001 TO 65535	
OPC=OPERATIONAL STATUS CODE	0,3	<i>0=UNCALIBRATED, 3=CALIBRATED</i>
TNI=TARGET NETWORK ID	1 TO 99	<i>FROM EXTERNAL DIP SWITCHES</i>
TST=TARGET STATUS	0 TO 255	<i>(See TST Information, Page 39)</i>
VP = VERTICAL POSITION, COUNTS	-32768 TO 32767	<i>1μm = 2 COUNTS (A-1519)</i>
	“	<i>1μm = 4 COUNTS (A-1520)</i>
VCO= SENSOR CENTER OFFSET	-4000 TO 4000	<i>1μm = 2 COUNTS (A-1519)</i>
	“	<i>1μm = 4 COUNTS (A-1520)</i>
BAT=BATTERY VOLTAGE	0 TO 5000	<i>MILLIVOLTS</i>
TEMP=INTERNAL TEMPERATURE (COUNTS)	-160 TO 800	<i>1 COUNT=1/16°C</i>
CHK=PACKET CHECKSUM		

Notes:

Two byte (integer) values (for example, SN, CHK) are in least significant byte, most significant byte order. For example, Byte 4 = 57 (39 HEX), Byte 5 = 48 (30 HEX), then SN = 12345 (3039 HEX).

VCO = Mechanical offset between the sensor's electrical center and the target's mechanical center. For factory use only.

CHK (Checksum) = Two's complement (negation) of the sum of bytes 1 to 16

Dual Axis Data Packet
(R-1307C, R-1307-2.4ZB Readouts or A-1519-2.4ZB, A-1520-2.4ZB targets)

BYTE 1	2	3	4	5	6	7	8	9	10	11	12	13	14	15	16	17	18
SOM	LEN	DEV	SN		OPC	TNI	TST	VP		VCO		BAT		TEMP		HP	
19	20	21	22														
HCO		CHK															

Packet Length: 22 bytes (Including two Checksum bytes)

	DEC	NOTES
	-----	-----
SOM = START OF MESSAGE	64	
LEN = LENGTH OF MESSAGE	22	
DEV = DEVICE TYPE	19,20	<i>A-1519 = 19 DEC</i>
SN= SERIAL NUMBER	00001 TO 65535	
OPC=OPERATIONAL STATUS CODE	0,3	<i>0=UNCALIBRATED,</i> <i>3=CALIBRATED</i>
TNI=TARGET NETWORK ID	1 TO 99	<i>FROM EXTERNAL DIP</i> <i>SWITCHES</i>
TST=TARGET STATUS	0 TO 255	(See Page 4)
VP = VERTICAL POSITION, COUNTS	-32768 TO 32767	<i>1 μm = 2 COUNTS (A-1519)</i> <i>"</i> <i>1 μm = 4 COUNTS (A-1520)</i>
VCO= VERTICAL CENTER OFFSET	-4000 TO 4000	<i>1 μm = 2 COUNTS (A-1519)</i> <i>"</i> <i>1 μm = 4 COUNTS (A-1520)</i>
BAT=BATTERY VOLTAGE	0 TO 5000	<i>MILLIVOLTS</i>
TEMP=INTERNAL TEMPERATURE (COUNTS)	-160 TO 800	<i>1 COUNT=1/16°C</i>
HP = HORIZONTAL POSITION, COUNTS	-32768 TO 32767	<i>1 μm = 2 COUNTS (A-1519)</i> <i>"</i> <i>1 μm = 4 COUNTS (A-1520)</i>
HCO= HORIZONTAL CENTER OFFSET	-4000 TO 4000	<i>1 μm = 2 COUNTS (A-1519)</i> <i>"</i> <i>1 μm = 4 COUNTS (A-1520)</i>
CHK=PACKET CHECKSUM		

Notes:

Two byte (integer) values (for example, SN, CHK) are in least significant byte, most significant byte order. For example, Byte 4 = 57 (39 HEX), Byte 5 = 48 (30 HEX), then SN = 12345 (3039 HEX).

VCO,HCO = Mechanical offsets between the sensor's electrical center and the target's mechanical center. For factory use only.

CHK (Checksum) = Two's complement (negation) of the sum of the bytes 1 to 20.

TST – Target Status Byte (All Packet Types)

BIT ORDER

EXAMPLE: 116 DEC, (01110100
BINARY) =>

BIT 7	BIT 6	BIT 5	BIT 4	BIT 3	BIT 2	BIT 1	BIT 0
0	1	1	1	0	1	0	0

ILL:

(INCIDENT LIGHT LEVEL)
0 - 11 NORMAL RANGE
12-14 CAUTION. NEAR
SATURATION
15 SATURATED

BIT 7	0	0	0	0	0	0	0	0	1	1	1	1	1	1	1	1
BIT 6	0	0	0	0	1	1	1	1	0	0	0	0	1	1	1	1
BIT 5	0	0	1	1	0	0	1	1	0	0	1	1	0	0	1	1
BIT 4	0	1	0	1	0	1	0	1	0	1	0	1	0	1	0	1
ILL =>	0	1	2	3	4	5	6	7	8	9	10	11	12	13	14	15

BACKGROUND LIGHT
PERIODICITY,
SYNCHRONIZATION MODE

PERIODICITY=>	50/100Hz	60/120Hz	NONE	UNSTABLE
BIT 3	0	0	1	1
BIT 2	0	1	0	1

USB PORT ACTIVITY
INDICATOR

BIT 1	1 = AUX. USB PORT ACTIVE	0 = RADIO/RS-485 ACTIVE
BIT 0	1 = LASER NOT DETECTED	0 = LASER DETECTED

LASER DETECTION STATUS

Appendix G – Troubleshooting Guide

Problem	Possible Solutions
1 <i>Laser turret spinning and A-1519/1520 target not detecting laser (target LED not illuminated)</i>	<ul style="list-style-type: none"> • Power off laser and turn back on (all L-740 and L-730 series lasers have a power protection circuit that needs to be reset if a power surge causes the laser to turn off). • Turn off rotation of laser if the beam is OK and check target battery. • Check where beam is hitting target. If it hits too low, target will not turn on.
2 <i>Turret spinning; laser beam not on</i>	<ul style="list-style-type: none"> • Power off laser and turn back on. If the laser does not power on, then it's possibly a blown laser diode. Return to HLI for repair.
3 <i>Laser beam on; turret not spinning</i>	<ul style="list-style-type: none"> • Ensure rotation switch is turned on. • Ensure rotation speed knob is turned up. • Check batteries – if the battery is low, there may not be enough voltage to spin the turret, but the laser may still be visible. • Environment is too cold. Laser cannot be used below 32 degrees F (0 degrees C). • Belt drive may be broken. Return to HLI repair.
4 <i>Laser not spinning and no laser beam</i>	<ul style="list-style-type: none"> • Ensure power supply is connected. • Replace batteries in the battery pack. • Check power supply connector. Widen split in pin inside the female connector on the laser with a small screwdriver. • Check A/C power source. Use second A/C power supply if available.
5 <i>Noisy target (A-1519/1520) readings on PDA</i>	<ul style="list-style-type: none"> • NOTE: On average the user can expect .00002 in/ft to .00005 in/ft (0.0025 mm/m--0.004 mm/m) of noise in good operating conditions. • Check for vibration in laser instrument stand (tripod) or surface the laser is sitting on. If laser is mounted on a machine tool, try turning machine tool off. • For very noisy readings, check for rotary lights (like those on a fork lift) or strobe lights (this will look like a “laser” to the target). • Check for air turbulence – air conditioning vents right over target? Check for open doors in summer or winter. See manual for Atmospheric Conditions. • Turn off the rotation of the laser and slowly rotate is by hand to check for reflections from metal surfaces. Dim overhead lights if possible. • Check for excess background light (use light shields). A warning may pop up on PDA display. • Ensure only one laser is hitting the target at a time. Turn off other laser plane rotation to see if this helps. • Ensure the target is facing/pointing directly at the laser (within ± 5 degrees). • Check light frequency (50 Hz vs. 60 Hz for background light). For correction feature of A-1519/1520 targets, see Target Utility Manual. North & South America is 60 Hz. Europe, Australia and parts of Asia are 50 Hz. • If PDA is plugged in, try unplugging PDA from A/C adapter. • Check for possible radio interference.

6	<i>No target readings in PDA. Target LEDs illuminated (means target is detecting laser)</i>	<ul style="list-style-type: none"> • Check radio receiver battery. Plug in A/C adapter to ensure it has power. • Ensure “check box” to the left of the display window in Read9 (see manual) is checked for each target. • Ensure channel setting (system ID) on A-1519/1520 matches the setting in PDA (see Read9 Manual). • Ensure target ID on A-1519/1520 is set to 1-4 for first screen or 5-8 in second screen in Read9. • Target is too close to laser (target LED’s will blink). • Check for reflections. • Check for strobe lights and rotary lights. • Check for excess background light (normally target LEDs will blink). • Plug target into computer via USB cable and open Target Utility software. If software shows reading, then there is probably a problem with the radio. • Ensure PDA has same radio frequency as target (900 MHz or 2.4 GHz). • Reset target (use paper clip in hole near Target ID/Channel Selector Panel). • Laser could be hitting too low or high on target window (it should be near the window). It’s possible for the laser to activate the auto wake up feature of target, but not enough of the beam is hitting the PSD (target sensor) to get a reading.
7	<i>No target readings in software. Target LED illuminated</i>	<ul style="list-style-type: none"> • Ensure A-910 radio base station is connected to USB port. • Ensure the correct COM port is selected for the USB bridge controller – see Windows Device Manager (must be lower than COM10). • Check Device Manager in Windows Control Panel. Set COM port for USB bridge controller lower than COM10. • Ensure the correct target ID is chosen in Machine Tool Geometry or Read8 software. • Ensure channel setting (system ID) on A-1519/1520 matches the setting in A-910 (see the Target Utility Manual). • Ensure SND/RC LEDs on A-910 are blinking (see the Target Utility Manual). • Ensure ACTUAL TARGETS (RADIO in Plane5) is selected in Read8, Plane5 or Machine Tool Geometry software. • Ensure antenna is connected to A-910. • Target may be too close to laser (target LED’s will blink). • Check for excess background light (normally target LEDs will blink). • Ensure A-910 radio base station has same radio frequency as target (900 MHz or 2.4 GHz). • Laser could be hitting too low or high on target window (it should be near the window). It’s possible for the laser to activate the auto wake up feature of target, but not enough of the beam is hitting the PSD (target sensor) to get a reading.
9	<i>“OFF TGT” shown in target display – PDA</i>	<ul style="list-style-type: none"> • Radio communication is working, but the target does not “see” the laser. <ul style="list-style-type: none"> ▪ Ensure laser beam is not blocked. ▪ Ensure laser beam is bright. ▪ Check laser power supply, especially if using a battery pack.
10	<i>Cannot see level vials</i>	<ul style="list-style-type: none"> • Turn on level light switch. • Turn on master power switch. • Check power supply connection.
11	<i>“Runtime Error” in</i>	<ul style="list-style-type: none"> • Do not unplug the A-910 from the USB port while still using the program.

	<i>software</i>	<ul style="list-style-type: none"> • Report to HLI the exact key strokes that created the Runtime Error.
12	<i>Software crashes upon loading</i>	<ul style="list-style-type: none"> • Ensure USB/Serial Converter cable is connected to the laptop's USB port. If problem persists, contact HLI.
13	<i>PDA locks up</i>	<ul style="list-style-type: none"> • Hit RESET switch <ul style="list-style-type: none"> ▪ Dell PDA – RESET is on right hand side of the back of PDA, near the lower right corner of the radio module. ▪ HP IPAQ – RESET is on bottom end of PDA.
14	<i>PDA turns off automatically</i>	<ul style="list-style-type: none"> • Check the Power Saving Options in the PDA (see PDA manual for details).
15	<i>PDA is frozen</i>	<ul style="list-style-type: none"> • Check the lock switch on the side of the PDA. If that does not work, press RESET.

Appendix H – Care and Cleaning of Target Optics

The proper care and cleaning of optical windows and/or lenses of Hamar Laser's position-sensing devices (targets) assures optimum performance. Contaminants on an optical surface increase scatter, absorb laser energy, and eventually degrade the accuracy of the position-sensing devices. Because cleaning any precision optics risks damaging the surface, optics should only be cleaned when absolutely necessary. When cleaning is required, we recommend the following supplies and procedures.

Required Supplies

- **Optics Cleaning Tissue:** Soft, absorbent, lint-free lens tissue
- **Swabs:** Cotton swabs with wooden handles or polyester swabs with polypropylene handles
- **Dust Blower:** Filtered dry nitrogen blown through an antistatic nozzle is best. Canned dusters, such as Dust-Off, will also work.
- **Mild Soap solution:** Neutral soap, 1 percent in distilled water. Avoid scented, alkali, or colored soap such as liquid dishwashing detergents or hand soap. Ten drops of green soap (available at a pharmacies and optical cleaning suppliers) per 100 cc of distilled water is an acceptable alternative.
- **Isopropyl Alcohol:** Spectroscopic grade. Over-the-counter alcohol contains too much water and may have impurities.
- **Acetone:** Spectroscopic grade. Do not use over-the-counter Acetone, such as the type intended for nail polish removal.

NOTE: *When cleaning precision optics, even with the best quality optical cleaning tissue, use gentle pressure to avoid scratching the surface or damaging the optical coating(s). Always wipe using a figure-eight motion in one direction (begin at the top and work toward the bottom in a figure-eight motion). Use only moistened (not soaked) optical cleaning tissue, Swabs and Spectroscopic grade Acetone and Isopropyl Alcohol. Never spray any type of liquid directly on the device or submerge any part of the device.*

Removing Dust

Dust can bind to optics by static electricity. Blowing only removes some of the dirt. The remainder can be collected by using wet alcohol and Acetone swabs wrapped with optical lens tissue. Acetone dries rapidly and helps to eliminate streaks.

1. Blow off dust.
2. If any dust remains, twist lens tissue around a cotton swab moistened in alcohol and repeat as necessary.
3. Repeat using Acetone.

Cleaning Heavy Contamination

Fingerprints, oil, or water spots should be cleaned immediately. Skin acids attack coatings and glass and can leave permanent stains. Cleaning with solvents alone tends to redistribute grime.

1. Blow off dust.
2. Using a soap-saturated lens tissue around a swab, wipe the optic gently. Repeat as necessary.
3. Repeat using a distilled water-saturated lens tissue wrapped around a swab.
4. Repeat using an alcohol-saturated lens tissue wrapped around a swab.
5. Repeat using an acetone-saturated lens tissue wrapped around a swab.

Appendix I –A-910-2.4ZB Radio Utility

Pre-installing the Common USB Port Driver

This driver is required for the A-910-2.4ZB/A-910-2.4XBE Transceiver and to communicate with targets via the computer’s USB port. The driver creates a virtual COM Port that is recognized by the applications as a standard serial port.

Note: You must pre-install this driver prior to connecting the device(s) to the computer through the USB port.

Installing the Driver

4. Insert the flash drive into the target computer.
5. Open the flash drive and locate the driver installation executable (e.g., CP210xVCPInstaller.exe).
6. Double-click the executable to run the installer.
Follow the on-screen instructions to complete the installation..



Figure 40 - USB Common Driver Install

Installing the A-910 Utility Software

1. Insert the flash drive into the target computer
2. Open the flash drive and locate the driver installation executable
3. Locate the **Setup** icon and click to initiate the installation process. Click **NEXT** to continue.
4. Click **Browse** to select an installation folder different from the default folder (optional).
5. Click **Next** to continue. Once the installation is complete, the **Installation Complete** message displays. Select **Close**.

Configuring the Hardware and Utility Settings

1. Insert the A-910 dongle into any unused USB port (see Figure 41). The computer should automatically assign a COM port number to the dongle.
2. Start the A-910 Utility Software. The software should display the COM port assigned to the A-910-ZB dongle (see Figure 42). If the utility does not automatically detect the COM port, it must be manually selected.
3. The Target System ID or R-1307 CH (channel) is the number associated with the A-1519/1520 targets or R-1307 Readout. If using both the A-1519/1520 and an R-1307 Readout, both need to be set to the same System ID and channel (see Figure 43). For further information, see **Manually Selecting the COM Port** on Page 46.



Figure 41 – A-910-2.4ZB Dongle

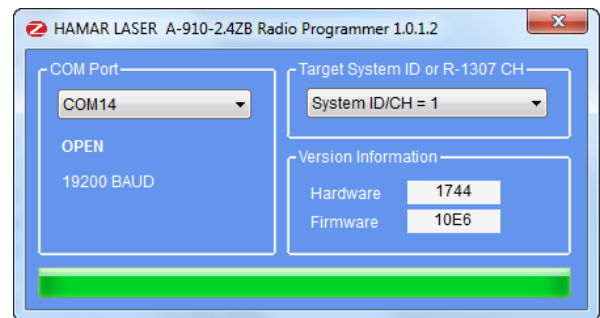

Figure 42 – A-910 Utility showing the COM Port, System ID and Channel settings

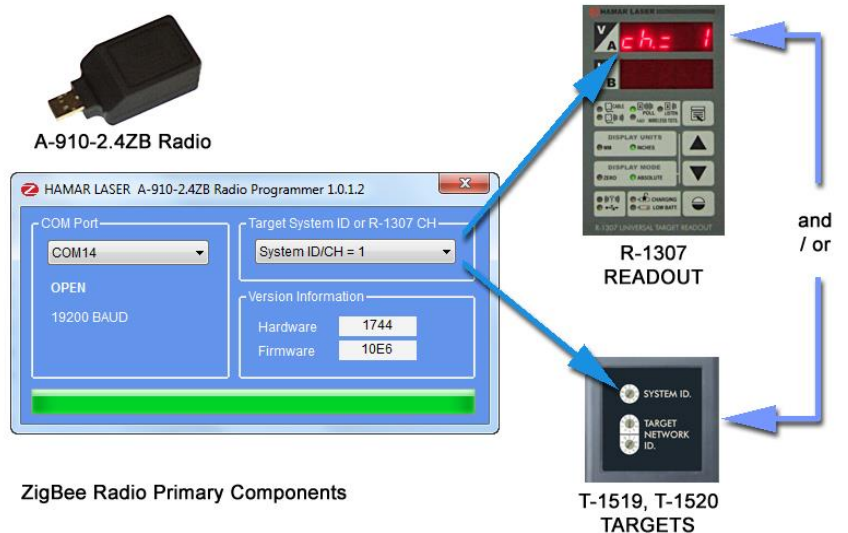

Figure 43 – System ID Setup

Manually Selecting the COM Port

The A-910 Utility should automatically detect the COM Port upon startup. If not, use the following steps to locate the correct COM Port.

For Windows 10 and Windows 11:

1. Open Device Manager:

- Press Win + X and select Device Manager from the menu.
- Alternatively, you can search for "Device Manager" in the Start menu.

2. Locate the Device:

- In the Device Manager window, expand the Ports (COM & LPT) section.
- Find the device for which you want to change the COM port (e.g., "Silicon Labs CP210x USB to UART Bridge").

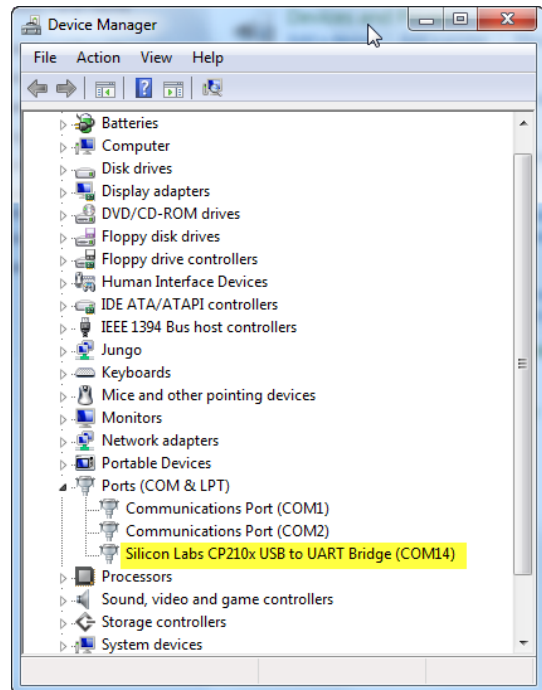

3. Open Device Properties:

- Right-click the device and select Properties.
- In the Properties window, go to the Port Settings tab.

4. Advanced Settings:

- Click on the Advanced button.
- In the Advanced Settings window, you'll see a section labeled COM Port Number.

5. Change the COM Port:

- Click the drop-down menu next to COM Port Number and select an available COM port number from the list.
- Click OK to save the changes.

6. Apply and Close:

- Click OK in the Properties window to apply the changes.
- Close the Device Manager.

Notes:

- Note the COM Port listed and select that COM Port in the A-910 Zigbee Utility software using the drop-down arrow.
- If you do not see the Ports (COM & LPT) section, it may mean that no devices using COM ports are currently connected or detected. Ensure your device is properly connected and its drivers are installed.

Appendix J –Installing the A-1519 Light Shield

If excessive background light causes a warning to display on the PDA, an optional light shield may be installed on the A-1519 Target as follows:

1. Roll each set screw in Loctite

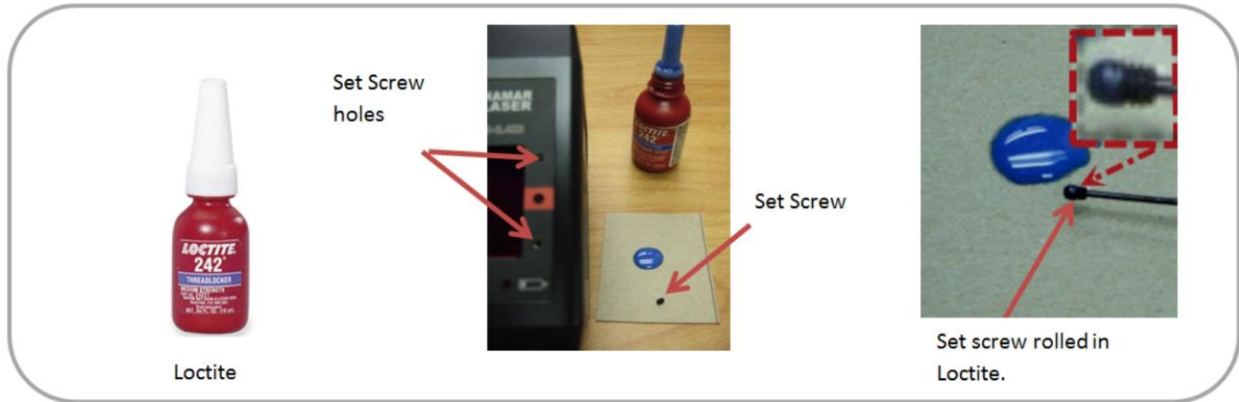

2. Install set screws in the holes on the A-1519 Target



3. Install the light shield to the target

